

K15

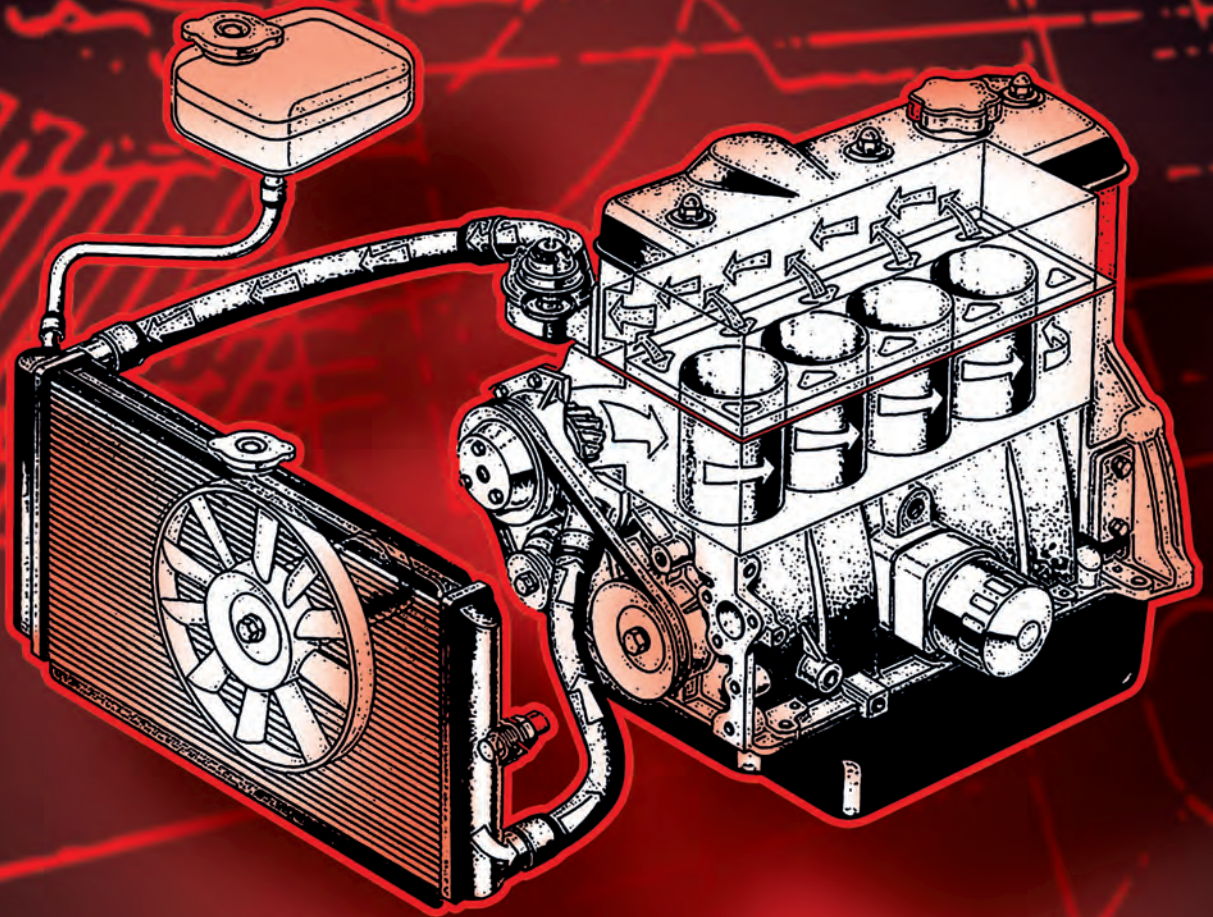

KS TOOLS

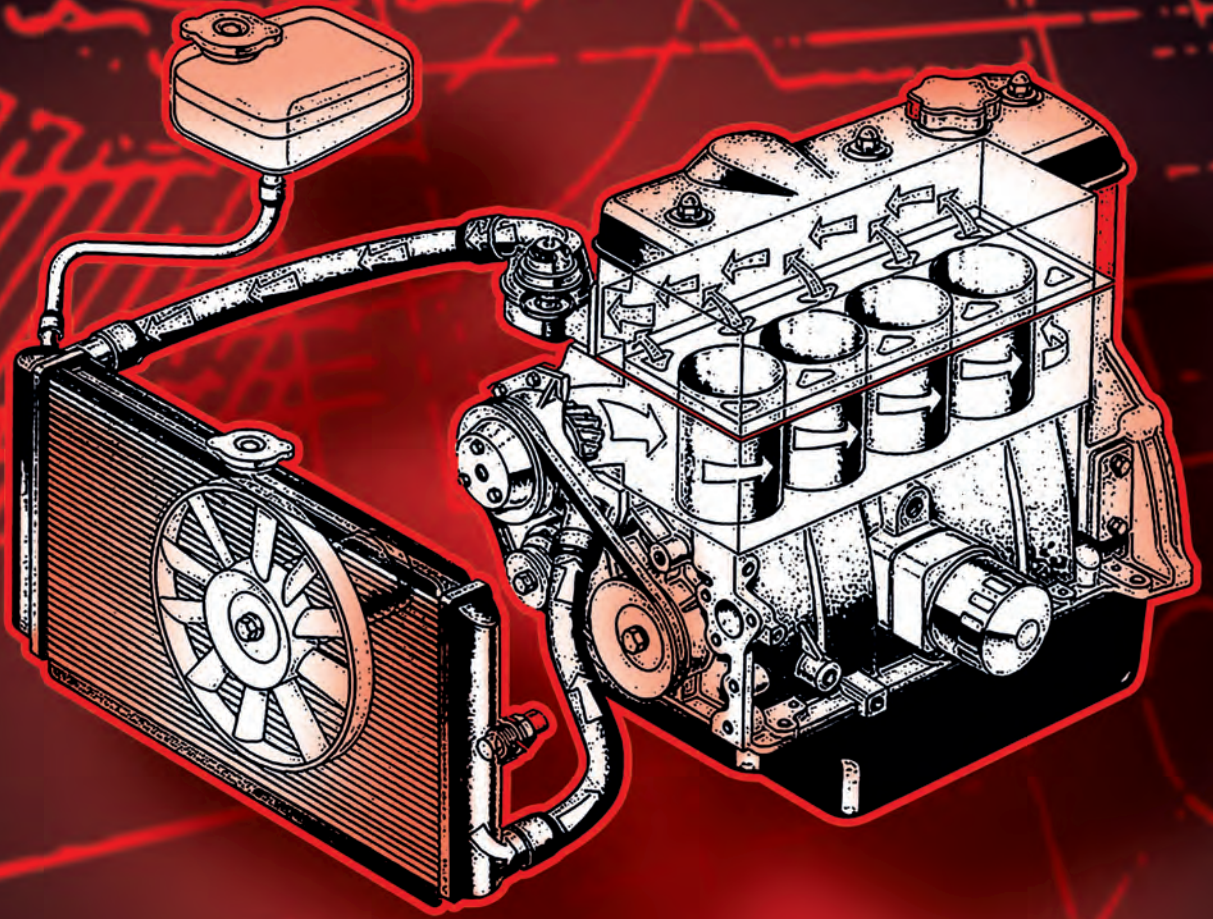



Innovation is
our mission!



	PAGE
WATER PUMP TEST	160
WATER PUMP TOOL	160
COOLING SYSTEM VACUUM FILLING DEVICE	160 - 161
COOLING SYSTEM CONE TEST ADAPTER	161
PRESSURE TEST PUMPS	161
COOLER ADAPTER	162 - 164
COOLING SYSTEM DIAGNOSIS SYSTEM SET	164
CYLINDER HEAD LEAK TESTER	165
THERMAL SWITCH SOCKET	165
LOCKING SCREW TURNER	165
COUNTER HOLD TOOL	166 - 167
FROST PROTECTION AND COOLANT WATER TESTER	167 - 168
TEMPERATURE MEASURING DEVICE	168
HOSE CLAMP TOOL	168 - 172
HOSE CLAMP TOOLS	172 - 173
DRIP PANS	173
MEASURING BEAKER, JUG AND FUNNEL	174
TRANSFER PUMPS	174 - 175

WATER PUMP TEST

Water pump testing set

- Makes an effective display of the cooling fluid flow possible
- Not necessary to remove the water pump
- Test carried out on running engine
- Time-saving diagnosis



150.9020	8 pcs	Water pump testing set	520
----------	-------	------------------------	-----

consists of:

X			
150.9021	1	Measuring device (low pressure 0-15 psi)	192
150.9022	2	Dummy plug	2
150.9023	1	Rubber pipe sealant set, 2 parts	63
150.9025	1	6 mm plastic hose, 2 m long	30
150.9026	1	Hose connector with external thread	52
150.9027	1	Pipe plug	130

WATER PUMP TOOL

Holding wrench for water pump belt pulleys

- Ideal for locking and releasing during assembly and disassembly of water pump belt pulleys
- Easy to remove fixed screws
- Internal square drive allows for lengthening possibilities
- Chrome vanadium



150.3026	L mm	kg
	250.0	490

Holding wrench for water pump belt pulleys for low-down water pumps

- Ideal for locking and releasing during assembly and disassembly of water pump belt pulleys
- Easy to remove fixed screws
- For low-down water pumps on engines with air condition
- Chrome vanadium

Application range: Audi, Volkswagen (engines with air condition), etc.



150.3028	L mm	kg
	300.0	560

Volkswagen water pump removal tool set

- Ideal for the quick and easy removal of the water pump or the water pump's gear on diesel engines
- Also suitable for turning the crank shaft to the TDC position as well as holding the fixing screws when removing
- Time saving
- Robust design
- Special steel

Application range: Volkswagen (Touareg 2.5 Litre straight 5 cylinder diesel engine (R5) > 2003 with engine codes: MKB, BAC, BLK, BPD, BPE), Volkswagen (Transporter Multivan T5 LT 2.5 Litre straight 5 cylinder diesel engine (R5) >2004 with engine codes MKB, AXD, AXE, BLJ, BNZ, BPC)

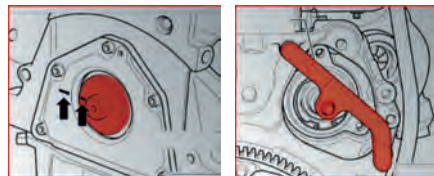

700.1900	3 pcs	Volkswagen water pump removal tool set	1.10
----------	-------	--	------

consists of:

700.1901	Volkswagen water pump puller	333
700.1902	Volkswagen crank shaft securing	105
700.1903	Volkswagen water pump drive wheel puller	303

Water pump fixing tool for Opel

- Ideal for quick and easy assembly and disassembly of water pumps
- Required to secure the water pump belt pulley
- Time saving
- Robust design
- Special steel

Application range: Opel Astra, Insignia, Signum, Omega, Speedster, GT, Vectra, Zafira, etc. with engine code: A 20 NHT, Z 20 NET, Z 20 NHH, Z 22 SE, Z 22 SE, Z 22 XE, Z 22 YH



700.1905	Ø mm	Water pump fixing tool for Opel	400
	100.0		

COOLING SYSTEM VACUUM FILLING DEVICE

Cooling system vacuum filling valve

- Ideally suited to the filling and testing of the tightness of the cooling system
- Includes valves, connections and dial gauge
- With supporting chain to hang it up



150.1960	Cooling system vacuum filling valve	577
----------	-------------------------------------	-----

Coolant system filling hose

- Ideally suited to filling the coolant system
- Includes quick coupling
- Clear
- With suction head base



150.1961	L mm	kg
	1600.0	208

Vacuum cooling system filling device

- Universally suitable for the filling of the cooling system of current common vehicles
- Through production of a vacuum within the cooling system the new coolant becomes of an even density sucked into the system
- During the vacuum process the cooling system is tested simultaneously for density
- Bubble free filling prevents air inclusions in the cooling system
- A cleaning of the cool system is unnecessary
- Universally suitable through conical rubber connection piece
- In durable plastic storage case

Please note: Filling device does not empty automatically the old coolant!



Technical data:

Manometer: bis max. -30 PSI / -1 Bar
 Air pressure: min. 550kPa - max. 690kPa
 Air consumption: max. 180l/min / 690kPa
 Low pressure: 0.85 bar at 690kPa

150.2070	4 pcs	Vacuum cooling system filling device	1.88
----------	-------	--------------------------------------	------

consists of:

150.2070-1	Refill Gun	1280
150.2070-28	Rubber cone small	60
150.2070-29	Rubber cone, large	65
150.2070-30	Tube 1,5m	200

COOLING SYSTEM CONE TEST ADAPTER

Cooling system cone test adapter

- For testing pressure and diagnosing leaks in the coolant system
- The pressure generated holds the matching rubber cone in the cooler or expansion tank opening
- Can be fitted directly onto the cooler or expansion tank
- Secure fit
- Simple handling
- Can be used with manual vacuum pump or filling device
- Robust design

Application range: Cars, transporters, etc.



	Ø mm	H mm	g
455.0136	17,0 - 31,0	180,0	62
455.0137	24,0 - 39,0	180,0	77
455.0138	34,0 - 50,0	180,0	110

Cooling system cone set 17.0 - 50.0 mm

- For testing pressure and diagnosing leaks in the coolant system
- The pressure generated holds the matching rubber cone in the cooler or expansion tank opening
- Can be fitted directly onto the cooler or expansion tank
- Secure fit
- Simple handling
- Can be used with manual vacuum pump or filling device
- Robust design

Application range: Cars, transporters, etc.



455.0135	3 pcs	Cooling system cone set 17.0 - 50.0 mm	265
----------	-------	--	-----

consists of:

455.0136	Cooling system cone test adapter, Ø 17.0-31.0 mm	62
455.0137	Cooling system cone test adapter, Ø 24.0-39.0 mm	77
455.0138	Cooling system cone test adapter, Ø 34.0-50.0 mm	110

Cooling system expander cone test adapter

- For testing pressure and diagnosing leaks in the coolant system
- Also suitable for filling the cooling system alongside a filling valve
- The pressure generated holds the matching rubber cone in the cooler or expansion tank opening
- Can be fitted directly onto the cooler or expansion tank
- Secure fit due to expansion
- Removes need to purchase single adapters
- For nearly all vehicle manufacturers
- Simple handling
- Optimal use alongside KS Test pump 455.0111
- Robust design made from POM (polyoxmethylen)

Application range: Cars, transporters, etc.

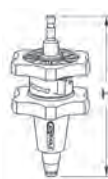

	Ø mm	H mm	g
455.0141	17,0 - 37,0	170,0	252
455.0142	28,0 - 41,0	170,0	280
455.0143	37,0 - 50,0	170,0	320
455.0144	47,0 - 60,0	170,0	410

Cooling system expander cones test adapter set 17.0 - 48.5 mm

- For testing pressure and diagnosing leaks in the coolant system
- Also suitable for filling the cooling system alongside a filling valve
- The pressure generated holds the matching rubber cone in the cooler or expansion tank opening
- Can be fitted directly onto the cooler or expansion tank
- Secure fit due to expansion
- Removes need to purchase single adapters
- For nearly all vehicle manufacturers
- Simple handling
- Optimal use alongside KS Test pump 455.0111
- Robust design made from POM (polyoxmethylen)

Application range: Cars, transporters, etc.



455.0140	4 pcs	Cooling system expander cones test adapter set 17.0 - 48.5 mm	1.33
----------	-------	---	------

consists of:

455.0141	Cooling system adapter No.1, Ø 17-24 mm	252
455.0142	Cooling system adapter No.2, Ø 28-31.5 mm, stepped	280
455.0143	Cooling system adapter No.3, Ø 37-39.5 mm, stepped	320
455.0144	Cooling system adapter No.4, Ø 47-48.5 mm, stepped	410

PRESSURE TEST PUMPS

Hand pump with manometer

- Ideal for testing tightness in the coolant system and heating
- Measurement range from 0 bar 2.5
- With pressure-release valve
- Includes hose



150.1931	0 - 2.5	443
----------	---------	-----

Hand pump with manometer

- Ideal for testing tightness in the coolant system and heating
- Measurement range from 0 bar 2.5
- With pressure-release valve
- Manometer with protective rubber cap
- Robust design



455.0111	Hand pump with manometer	473
----------	--------------------------	-----

COOLER ADAPTER

Cooling system test socket R123/R124

- Ideally suited to test the cooler cover
- Serves as an adapter between the hand pump and cooler cover
- Double connection
- Black



150.1932	Cooling system test socket R123/R124	42
----------	--------------------------------------	----

Cooling system test socket R123/R125

- Ideally suited to test the cooler cover
- Serves as an adapter between the hand pump and cooler cover
- Double connection
- Blue



150.1933	Cooling system test socket R123/R125	42
----------	--------------------------------------	----

Cooling system bayonet adapter, small

- Ideal for testing the coolant system
- With quick coupling
- Aluminium

Application range: Honda, Toyota, Suzuki, Mitsubishi, Chrysler, Acura, Lexus, etc.



150.1916	Cooling system bayonet adapter, small	60
----------	---------------------------------------	----

Cooling system bayonet adapter, medium

- Ideal for testing the coolant system
- With quick coupling
- Aluminium

Application range: Ford, Peugeot, Subaru, Chrysler, Acura, GM, Mitsubishi, Nissan, Mazda, Toyota, Infinity, etc.



150.1917	Cooling system bayonet adapter, medium	80
----------	--	----

Cooling system bayonet adapter, large

- Ideal for testing the coolant system
- With quick coupling
- Aluminium

Application range: Mercedes (W123, W126, W124, W201, Unimog), GM (Buick), Jeep, etc.



150.1918	Cooling system bayonet adapter, large	110
----------	---------------------------------------	-----

Coolant system adapter M 34 x 3.0

- Ideal for testing the coolant system
- With quick coupling
- External thread
- Violet
- Made from shock-resistant plastic

Application range: Toyota (RAV 4, Previa), etc.



150.1954	Coolant system adapter M 34 x 3.0	51
----------	-----------------------------------	----

Coolant system adapter M 42 x 2.5

- Ideal for testing the coolant system
- With quick coupling
- Internal thread
- Purple
- Made from shock-resistant plastic

Application range: Mercedes (A class, Sprinter >2009), etc.



150.1951	Coolant system adapter M 42 x 2.5	73
----------	-----------------------------------	----

Coolant system adapter M 42 x 3.0

- Ideal for testing the coolant system
- With quick coupling
- Internal thread
- Brown
- Made from shock-resistant plastic

Application range: Citroën, Fiat, Alfa Romeo, Mini, Peugeot, Jeep, Sterling, Renault, Saab, Volvo, etc.



150.1942	Coolant system adapter M 42 x 3.0	66
----------	-----------------------------------	----

Coolant system adapter M 45 x 3.0

- Ideal for testing the coolant system
- With quick coupling
- Internal thread
- Red
- Made from shock-resistant plastic

Application range: Audi, Volkswagen, etc.



150.1946	Coolant system adapter M 45 x 3.0	56
----------	-----------------------------------	----

Coolant system adapter M 48 x 4.0

- Ideal for testing the coolant system
- With quick coupling
- Internal thread
- Grey
- Made from shock-resistant plastic

Application range: BMW (3 series E36, E46, E90, 5 series E34, E39, 7er E32, E38), etc.



150.1945	Coolant system adapter M 48 x 4.0	80
----------	-----------------------------------	----

Coolant system adapter M 46 x 3.0

- Ideal for testing the coolant system
- With quick coupling
- Internal thread
- Turquoise
- Made from shock-resistant plastic

Application range: Seat (Alhambra), Volkswagen (Sharan 1.8 T and 2.8 L)



150.1953	Coolant system adapter M 46 x 3.0	64
----------	-----------------------------------	----

Coolant system adapter M 50 x 2.5

- Ideal for testing the coolant system
- With quick coupling
- Internal thread
- Green
- Made from shock-resistant plastic

Application range: Ford, Opel (Insignia, Corsa D), Jaguar, Land Rover, Ssangyoung, etc.



150.1947	Coolant system adapter M 50 x 2.5	86
----------	-----------------------------------	----

Coolant system adapter M 45 x 3.0

- Ideal for testing the coolant system
- With quick coupling
- Internal thread
- Moss green
- Made from shock-resistant plastic

Application range: BMW Mini >2008, PSA 2008-2010, etc.



150.1994	Coolant system adapter M 45 x 3.0	48
----------	-----------------------------------	----

Coolant system adapter M 48 x 2.5

- Ideal for testing the coolant system
- With quick coupling
- Internal thread
- Pink
- Made from shock-resistant plastic

Application range: Mazda (3), etc.



150.1950	Coolant system adapter M 48 x 2.5	75
----------	-----------------------------------	----

Coolant system adapter M 50 x 3.0

- Ideal for testing the coolant system
- With quick coupling
- Internal thread
- Light blue
- Made from shock-resistant plastic

Application range: BMW (5 series E60, F11, 6 series E63, E64, 7 series E65), etc.



150.1952	Coolant system adapter M 50 x 3.0	84
----------	-----------------------------------	----

Coolant system adapter M 46 x 3.0

- Ideal for testing the coolant system
- With quick coupling
- Internal thread
- White
- Made from shock-resistant plastic

Application range: Saab (Eco Power 9-3, 9-5)



150.1955	Coolant system adapter M 46 x 3.0	64
----------	-----------------------------------	----

Coolant system adapter M 50 x 2.5

- Ideal for testing the coolant system
- With quick coupling
- Internal thread
- Orange
- Made from shock-resistant plastic

Application range: Ford (Fiesta >1995, Focus >1998, Fusion >2006), Opel (Astra F and G, Corsa B, Tigra, Vectra), Porsche (911 >1999, Boxter >1997), Mercedes (ML-class, W163, W164), GM, Saab (900 1994-1998), Land Rover (Discovery 1989-2004), Range Rover 1988-1994, etc.



150.1941	Coolant system adapter M 50 x 2.5	62
----------	-----------------------------------	----

Coolant system adapter M 52 x 3.0

- Ideal for testing the coolant system
- With quick coupling
- Internal thread
- Yellow
- Made from shock-resistant plastic

Application range: Ford (Mondeo, C-Max >2003), etc.



150.1949	Coolant system adapter M 52 x 3.0	91
----------	-----------------------------------	----

Coolant system adapter M 52.5 x 3.0

- Ideal for testing the coolant system
- With quick coupling
- Internal thread
- Orange
- Made from shock-resistant plastic

Application range: Cadillac, Chevrolet, Fiat (Chroma), Ford, Isuzu, Mazda (6), Opel, Astra, Meriva, Zafira, Signum), Saab, Suzuki, etc.



150.1956	Coolant system adapter M 52.5 x 3.0	64
----------	-------------------------------------	----

Coolant system adapter M 58 x 3.0

- Ideal for testing the coolant system
- With quick coupling
- External thread
- Black
- Made from shock-resistant plastic

Application range: Volkswagen (Beetle, Golf, Sharan, Passat, T4, T5, Vento), etc.



150.1943	Coolant system adapter M 58 x 3.0	69
----------	-----------------------------------	----

Coolant system adapter M 60 x 4.0

- Ideal for testing the coolant system
- With quick coupling
- Internal thread
- Blue
- Made from shock-resistant plastic

Application range: Mercedes (C class, E class, S class), etc.



150.1948	Coolant system adapter M 60 x 4.0	90
----------	-----------------------------------	----

Coolant system adapter M 62 x 3.0

- Ideal for testing the coolant system
- With quick coupling
- External thread
- Black
- Made from shock-resistant plastic

Application range: Audi (A4, A5, A6), BMW, Volkswagen (Passat 1,9TDI, Golf 4 1,4FSI, Touran 1,4TSI), Škoda (Fabia 1.4), Porsche (Cayenne), etc.



150.1944	Coolant system adapter M 62 x 3.0	72
----------	-----------------------------------	----

COOLING SYSTEM DIAGNOSIS SYSTEM SET

Universal cooling system diagnostic service set

- Innovative and universal diagnosis device for testing the pressure in the cooling system as well as the pressure caps
- Suitable for almost all common vehicles with water-cooled engines thanks to the inflatable universal bladder sealing system
- Test cap with 6 special double-sided adapters
- Quickly find leaks in the cooling system, e.g. cylinder head seals, cooling unit, water pumps, hoses, etc.
- The pressure loss inspection is carried out via the manometer
- Quick and efficient use
- Measurement range from 0 bar 2.5
- In durable plastic storage case

Application range: for almost 95% of all vehicle manufacturers



150.2065	12 pcs Universal cooling system diagnostic service set	2.30
----------	--	------

consists of:

150.2065-1	Adapter A, blue	66
150.2065-2	Adapter B, yellow	44
150.2065-3	Adapter C, green	58
150.2065-4	Adapter D, red	55
150.2065-5	Adapter E, orange	71
150.2065-6	Adapter F, grey	81
150.2066	Adapter, blue, small	30
150.2067	Adapter, red, small	25
150.2068	Adapter, black, small	40
150.2044	Pressure pump	2000
150.2065-01	Universal connection adapter	129
150.2065-07	Control valve	50

MASTER Cooling system diagnostic service set

- Ideal compilation set for testing the cooling system as well as the pressure caps
- With cooling system filling valve
- Quickly find leaks in the cooling system, e.g. cylinder head seals, cooling unit, water pumps, hoses, etc.
- Suitable for all common vehicles with water-cooled engines, e.g. from Europe, Japan, USA, etc.
- The pressure loss inspection is carried out via the manometer
- Quick and efficient use
- Measurement range from 0 bar 2.5
- Includes thermometer
- In durable plastic storage case

Application range: for almost all vehicle manufacturers



150.1930	25 pcs MASTER Cooling system diagnostic service set	5.41
----------	---	------

consists of:

		Colour code	
150.1931	Hand pump with manometer		443
150.1960	Cooling system vacuum filling valve		577
150.1961	Coolant system filling hose		208
150.1932	Cooling system test socket R123/R124	●	42
150.1933	Cooling system test socket R123/R125	●	42
150.1916	Cooling system bayonet adapter, small		60
150.1917	Cooling system bayonet adapter, medium		80
150.1918	Cooling system bayonet adapter, large		110
150.1941	Coolant system adapter M 50 x 2.5	●	62
150.1942	Coolant system adapter M 42 x 3.0	●	66
150.1943	Coolant system adapter M 58 x 3.0	●	69
150.1944	Coolant system adapter M 62 x 3.0	●	72
150.1945	Coolant system adapter M 48 x 4.0	●	80
150.1946	Coolant system adapter M 45 x 3.0	●	56
150.1947	Coolant system adapter M 50 x 2.5	●	86
150.1948	Coolant system adapter M 60 x 4.0	●	90
150.1949	Coolant system adapter M 52 x 3.0	●	91
150.1950	Coolant system adapter M 48 x 2.5	●	75
150.1951	Coolant system adapter M 42 x 2.5	●	73
150.1952	Coolant system adapter M 50 x 3.0	●	84
150.1953	Coolant system adapter M 46 x 3.0	●	64
150.1954	Coolant system adapter M 34 x 3.0	●	51
150.1962	Rubber cone adaptor, 14-45 mm, L=75 mm		88
150.1963	Rod thermometer		27
150.1940	Wrench for adapter		50

CYLINDER HEAD LEAK TESTER

CO2 Cylinder head leak testing set

- For the locating of leaks on combustion engines
- Rational and dependable finding of cracks and leakages
- Potential CO2 content in the coolant solution is detected
- Ideally suited for the cylinder head, cylinder head seals and engine block
- Leakages are visible through discoloration of the test fluid
- For all current vehicles with water cooled engines (Gas, Diesel and Petrol)
- Automatic regenerating reaction fluid for multiple use
- In durable plastic storage case



				kg
150.1910	8 pcs	CO2 Cylinder head leak testing set	1.43	

consists of:

			kg
150.1911	Intake-squeeze bulb	30	
150.1912	Two way brass valve	120	
150.1913	Basic device with 2 Test chambers and cones	120	
150.1914	Reaction fluid, 250 ml	250	
150.1915	Empty container, 250 ml (for required fluid)	30	
150.1916	Bayonet Adaptor Gr 1	60	
150.1917	Bayonet Adaptor Gr 2	80	
150.1918	Bayonet Adaptor Gr 3	110	

THERMAL SWITCH SOCKET

Thermal switch sensor socket

- Ideally suited to the assembly and disassembly of hard-to-reach thermal switches
- Also for thermal switches with long contact pins or plastic casings, as well as switches with cables
- Slotted design
- Internal square to DIN 3120/ISO 1174 with ball reception
- For manual operation
- Phosphate
- Chrome molybdenum

Application range: Opel Corsa B, Volkswagen models >2006, etc.



	mm	L mm	kg
150.2123	29	90.0	500

Special socket wrench

- Open 6-point profile
- Suitable for assembling upper and side cables temperature sensors, thermal switches and other parts
- Also suitable for screwing in angled pipes
- Matt chrome
- Chrome vanadium



	mm	kg
150.3810	10,0	19
150.3811	11,0	41
150.3812	12,0	49
150.3814	14,0	69
150.3817	17,0	108
150.3819	19,0	135

Special socket wrench set

- Open 6-point profile
- Suitable for assembling upper and side cables temperature sensors, thermal switches and other parts
- Also suitable for screwing in angled pipes
- Matt chrome
- Chrome vanadium
- Clip mounting



			kg
150.3805	6 pcs	Special socket wrench set	460

consists of:

			kg
150.3810	Special socket wrench, 10 mm	19	
150.3811	Special socket wrench, 11 mm	41	
150.3812	Special socket wrench, 12 mm	49	
150.3814	Special socket wrench, 14 mm	69	
150.3817	Special socket wrench, 17 mm	108	
150.3819	Special socket wrench, 19 mm	135	

LOCKING SCREW TURNER

Exhaust locking screw turner with t-bar

- For damage-free screwing and unscrewing of the air vent locking screws on the cooler
- Special cross profile
- Universal use also for low height
- With t-bar
- Chrome plated and mirror polished
- Chrome vanadium

Application range: BMW

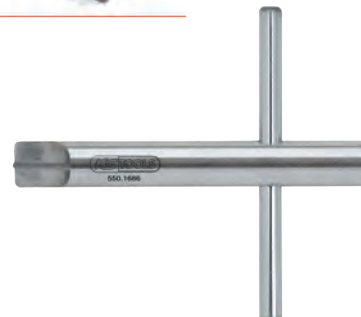

	Blade thickness mm	shank Ø mm	Blade height mm	Length mm	kg
550.1686	1.3	12.0	13.0	90.0	87

Exhaust locking screw turner with t-bar

- For damage-free screwing and unscrewing of the air vent locking screws on the cooler
- Special cross profile
- Universal use also for low height
- With t-bar
- Chrome plated and mirror polished
- Chrome vanadium

Application range: BMW

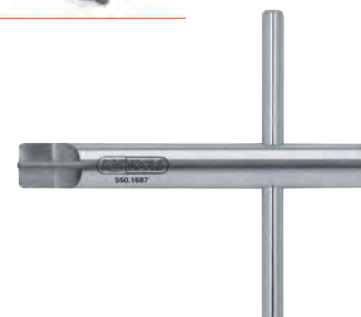

	Blade thickness mm	shank Ø mm	Blade height mm	Length mm	kg
550.1687	1.8	12.0	13.0	90.0	87



1
2
3
4
5
6
7
8
9
10
11
12
13
14
15
16
17
18
19
20
21
22
23
24
25
26

COUNTER HOLD TOOL

Counter hold wrench, 39.0 mm

- For turning the water pump
- To tighten / depressurize the drive belt
- Burnished
- Special steel

Application range: Opel/Vauxhall, GM OHC engines



1/2

Part No.	mm	Length mm	Weight g
516.1004	39	90.0	100

Counter hold wrench, 41.0 mm

- For turning the water pump
- To tighten / depressurize the drive belt
- Burnished
- Special steel

Application range: Opel/Vauxhall, GM OHC engines 1.2, 1.3, 1.4 and 1.6 l

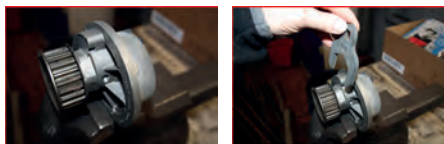

1/2

Part No.	mm	Length mm	Weight g
516.1002	41	90.0	110

Counter hold wrench, 46.0 mm

- For turning the water pump
- To tighten / depressurize the drive belt
- Burnished
- Special steel

Application range: Suitable for Opel and GM OHC engines



1/2

Part No.	mm	Length mm	Weight g
516.1001	46	90.0	120

Universal Visco ventilator wrench

- For removing the hubs and bleeding with viscous couplings
- Especially slim design
- Enables easy access
- PVC dipped handle
- Special steel

Application range: BMW, Ford, Opel, GM etc.



Part No.	mm	Suitable for	Weight g
150.3022	32	for clamping the viscous coupling drive shaft on BMW, Ford	300
150.3027	36	For counter holding the Visco coupling drive shaft BMW, Ford, GM	340
150.3023	41	for twisting the water pump on Opel and GM	422
150.3024	46	for twisting the water pump on Opel and GM	405

Visco ventilator wrench

- Ideally suited to removing the hubs on ventilators with viscous coupling
- Especially slim design
- Allows for easy access
- With suspension hole
- Special steel

Application range: Mercedes engines M103 (6 cylinder), M104 (6 cylinder 4 valve), M119 (8 cylinder 4 valve), M120 (12 cylinder 4 valve)

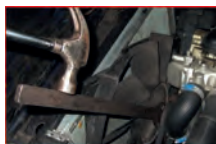

Part No.	mm	Length mm	Weight g
150.3301	65	400.0	472

Visco ventilator wrench

- Ideally suited to removing the hubs on ventilators with viscous coupling
- Especially slim design
- Allows for easy access
- Specially curved
- With suspension hole
- Special steel

Application range: Mercedes (engine: M 111.979, 112, 113, 119.985)

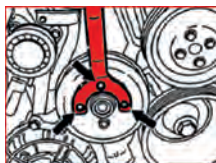

Part No.	Visco ventilator wrench	L mm	Weight g
150.3008	Visco ventilator wrench	410.0	370

Holding wrench for Visco ventilator

- For counter holding the ventilation valve when disassembling the Visco ventilator
- Especially slim design
- Allows for easy access
- Special steel

Application range: BMW engine M10, M20, M21, M30, M50, M51, M52, M52TU, M54, M56, M70, M73, S14 and S38



Part No.	Length mm	Weight g
150.3306	380.0	330

Ford fan hub wrench

- For the professional engine repair
- Simple assembly and disassembly of the Visco coupling rotor
- Makes it possible to secure the pulley wheel of the water pump and at the same time release the heating filter
- Special steel
- Very high degree of accuracy

Application range: Ford Transit (2001 - 2006)



1/2

Part No.	Pin key mm	Weight g
400.9014	69.0	133

Land Rover fan hub wrench set

- For counter holding the Visco coupling drive shaft
- Makes it possible to secure the pulley wheel of the water pump and at the same time release the heating filter
- Also suitable for the removal of the viscous connecting socket on the cooler ventilator
- Special steel

Application range: Land Rover Discovery II, Range Rover, Defender 1990-2006 with Td5 or V8 engines



Part No.	Quantity	Application	Weight g
400.4175	2 pcs	Landrover	18.29

consists of:

Part No.	Description	Weight g
400.0176	Holding wrench for Visco fan for Land Rover	1.05
400.0177	Visco fan wrench 36.0 mm for Land Rover	14.78

Mercedes belt disc wrench 8.0 mm

- Suitable for the installation and removal of the fan coupling and the belt disc
- Required when changing the water pump
- For hard-to-reach places
- With plastic-coated handle
- Chrome vanadium

Application range: Mercedes engines M102, M103, OM601, OM602, OM603, OM605, OM606

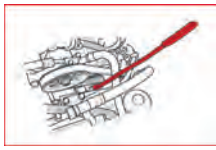

150.1303	2 pcs	Mercedes belt disc wrench 8.0 mm	460
----------	-------	----------------------------------	-----

consists of:

150.1227	Special wrench with 8.0 mm hexagonal drive, 450 mm	440
150.1307	Bit with 8.0 mm hexagonal drive for internal hexagonal screws 8.0 mm	20

Mercedes compressor belt disc wrench 10.0 mm

- Suitable for releasing the screws on the compressor belt disc
- Required when changing the water pump
- For hard-to-reach places
- With plastic-coated handle
- Chrome vanadium

Application range: Mercedes engines M102, M103, OM601, OM602, OM603, OM605, OM606



150.1304	2 pcs	Mercedes compressor belt disc wrench 10.0 mm	460
----------	-------	--	-----

consists of:

150.1227	Special wrench with 8.0 mm hexagonal drive, 450 mm	440
150.1308	Bit with 8.0 mm hexagonal drive for internal hexagonal screws 10.0 mm	20

Ventilator coupling counter hold for Mercedes

- Ideally suited to securing the ventilator coupling
- Especially slim design
- Allows for easy access
- Especially curved for use
- Special steel

Application range: Mercedes (engine: M 103, 104)

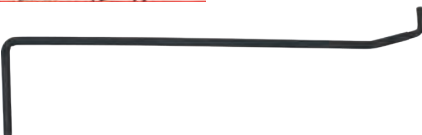
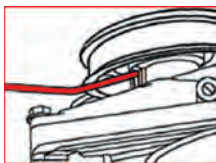

150.3009	Ventilator coupling counter hold for Mercedes	L mm	105
		300.0	

Ventilator hub wrench set

- For counter holding the Visco coupling drive shaft
- Makes it possible to secure the water pump's belt pulley and release the heating ventilator at the same time
- Also suitable for the removal of the viscous connecting socket on the cooler ventilator
- Special steel
- In durable plastic storage case

Application range: BMW, Mercedes and Ford



150.3320	12 pcs	Ventilator hub wrench set	1.89
----------	--------	---------------------------	------

consists of:

150.3008	Visco ventilator wrench	370
150.3009	Ventilator coupling counter hold for Mercedes Benz	105
150.3022	Viscous fan spanner, BMW, Ford, 32mm	300
150.3024	Viscous fan spanner, Opel, GM, 46mm	405
150.3027	Viscous fan spanner, BMW, Ford, GM, 36mm	340
150.3301	Visco ventilator wrench	472
150.3306	Holding wrench for Visco ventilator	330
150.3321	Adapter, short, Ø 20 mm	5
150.3322	Adapter, Ø 8 mm	22
150.3323	Adapter, Ø 10 mm	29
150.3324	1/2" Holding wrench	635
151.26025	BASIC key wrench, hex, short, 2.5mm	10

Pin-type face wrench set, seamlessly adjustable with interchangeable pins

- Universal application for common two-hole nuts
- With interchangeable pins
- Each double pin wrench is replacing 4 single key sizes
- Adjustable in diameter
- Phosphate finish
- Special steel
- In durable plastic storage case



150.3205	19 pcs	Pin-type face wrench set, seamlessly adjustable with interchangeable pins	1.56
----------	--------	---	------

consists of:

150.3206	Pin-type face wrench, adjustable, length 263 mm	485
150.3207	Pin-type face wrench, adjustable, length 215 mm	293
150.3208	Pin-type face wrench, adjustable, length 161 mm	155
150.3209	Pin-type face wrench, adjustable, length 115 mm	57
150.3210	Pin pair, Ø 2.37 mm	2
150.3211	Pin pair, Ø 2.90 mm	2
150.3212	Pin pair, Ø 4.87 mm	5
150.3213	Pin pair, Ø 5.91 mm	7
150.3214	Pin pair, Ø 6.87 mm	13
150.3215	Pin pair, Ø 7.92 mm	15
150.3216	Pin pair, Ø 9.87 mm	28
150.3217	Pin pair, Ø 11.90 mm	37

Universal timing gear holder set

- Ideally suited for almost all vehicle types
- Universal usable tool for locking, turning and fastening for stepped timing belts
- The overall length of 520 mm guarantees an optimal lever for loosening the timing belts reinforcement screws
- Stepless adjustment of Ø 40 - 220 mm - pin height: 35 mm
- Includes 4 pairs of screw on plugs
- With plastic coated handle
- Special steel

Application range: Timing belt wheels on camshafts and Injection pumps bleeding of wheels and couplings etc.

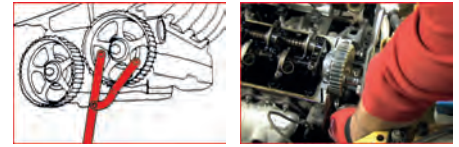

150.3000	11 pcs	Universal timing gear holder set	2.20
----------	--------	----------------------------------	------

consists of:

150.3001	Loosening lever 520 mm, adjustable	1120
150.3002	Peg, Ø 6 - 10 mm	100
150.3003	Peg, Ø 8 - 11 mm	50
150.3004	Peg, Ø 10 - 12 mm	40
150.3005	Peg, Ø 11 - 16 mm	40
150.3006	Fixing nut for pegs, knurled	20

FROST PROTECTION AND COOLANT WATER TESTER

Refractometer - optical tester for battery fluid and antifreeze

- For the quick and accurate testing of acidity in the battery fluid and the antifreeze content
- Can also be used for coolant and windscreen wiper fluid
- Adjustable eye piece with rubber viewing rest
- With automatic temperature compensation (ATC)
- Also suitable in ambient temperatures of less than 10°C
- Reading correction function by means of bimetallic measurement
- High quality design made from aluminium
- Good readability due to defined dividing lines
- Recalibration possible
- Includes calibration screwdriver and pipette
- In practical plastic case

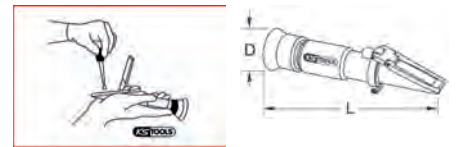

Technical data:

Battery acid:	acid density (measuring range 1.1 to 1.4 kg/l)
Coolant water Propylene:	temperature resistance (measuring range 0° to -50°C)
Coolant water Ethylene:	temperature resistance (measuring range 0° to -50°C)
Windscreen water:	antifreeze (measuring range 0° to -40° C)

550.1290	D mm	L mm	Glass base mm	1
	40.0	149.0	40 x 13	630

1
2
3
4
5
6
7
8
9
10
11
12
13
14
15
16
17
18
19
20
21
22
23
24
25
26

AdBlue refractometer - optical tester for battery fluid, antifreeze and AdBlue additives

- For the quick and accurate testing of the acidity of the battery fluid, the antifreeze content and the AdBlue additives
- Can also be used for coolant and windscreen wiper fluid
- Adjustable eye piece with rubber viewing rest
- With automatic temperature compensation (ATC)
- Also suitable in ambient temperatures of less than 10°C
- Reading correction function by means of bimetallic measurement
- High quality design made from aluminium
- Good readability due to defined dividing lines
- Recalibration possible
- Includes calibration screwdriver and pipette
- In practical plastic case

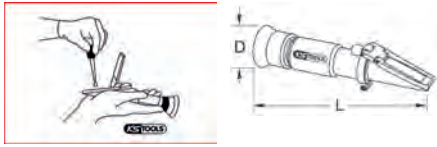

Technical data:

Battery acid:	acid density (measuring range 1.1 to 1.3 kg/l)
Coolant water Propylene:	temperature resistance (measuring range -25° to -50°C)
Coolant water Ethylene:	temperature resistance (measuring range -25° to -50°C)
Windscreen water:	antifreeze (measuring range -10° to -40° C)
AdBlue (VRA):	urea content (measuring range 30% - 35%)

	D mm	L mm	Glass face mm	kg
550.1285	40.0	160.0	40 x 13	480

Antifreeze tester

- For quick and precise testing of antifreeze
- For ethylene glycol/water mixture in the cooling circuit for passenger cars, commercial vehicles, etc.
- Also allows for a visual inspection for rust and other impurities
- Also suitable in ambient temperatures of less than 10°C
- Easy to read with the pendulum display (up to -50°C/-60°F)
- High-quality design
- Plastic housing
- Easy to read



		kg
550.1241	Antifreeze tester	120

TEMPERATURE MEASURING DEVICE

Rod thermometer

- Controls temperature of air streams through air channels
- Controls the water temperature
- With long and narrow measuring instruments
- Scale with °C and °F measurements



	L mm	Working range °C	Working range °F	kg
150.1963	1600.0	0 - 220	0 - 440	27

Digital rod thermometer

- Controls temperature of air streams through air channels
- Controls the water temperature
- With long, narrow measuring instruments
- Good readability
- Includes 9V block battery
- Includes hold function
- Includes LCD display



	Length mm	Working range °C	kg
150.1968	125.5	-50 - 150	145

Infrared thermometer

- Laser pistol for non contact temperature measurement
- Ideally suited for the automotive sector, industrial, and construction usage Chemical and foodstuffs industry
- Laser measuring beam with a red measuring point
- Illuminating Display
- LCD Digital display
- Automatic switching off
- Includes 9V block battery
- Stable plastic housing

Application range: In turning motors, difficult to access places, fluids, under current line directions, in heating appliances, gas and, air-conditioning, coolant systems, brake discs aggressive chemicals and groceries



Technical data:

Switchable:	°C / °F
Working range:	-50° - 550 °C
Switching mode for spectral range:	0,85 - 0,90 - 0,95 µm
Power output max:	1mW
Power requirement:	9V block battery

		kg
150.3040	Infrared thermometer	250



HOSE CLAMP TOOL

ERGOTORQUE® socket screwdriver

- 6 point
- Flexible
- Limited torque
- Double spiral shaft
- Plastic protective coating
- With hanging hole
- Chrome vanadium

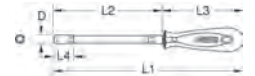

	mm	D mm	L1 mm	L2 mm	L3 mm	L4 mm	kg
911.1126	6	10.8	259.0	150.0	109.0	9.3	155
911.1127	7	11.7	259.0	150.0	109.0	10.0	155
911.1128	8	11.9	259.0	150.0	109.0	10.0	155
911.1125	10	12.5	279.0	170.0	109.0	14.3	170

ERGOTORQUEplus® socket screwdriver, extra long

- 6 point
- Flexible
- Limited torque
- Double spiral shaft
- Plastic protective coating
- Two component handle
- With hanging hole
- Chrome vanadium

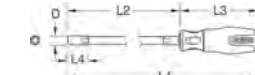

	mm	D mm	L1 mm	L2 mm	L3 mm	L4 mm	kg
911.1175	5	11.9	614.0	114.0	614.0	8.9	270
911.1176	6	10.9	614.0	114.0	614.0	11.3	280
911.1177	7	11.7	614.0	114.0	614.0	11.3	280
911.1178	8	11.7	614.0	114.0	614.0	11.3	280

ERGOTORQUE® screwdriver set

- Flexible blade with double spiral shaft
- Limited torque
- Plastic protective coating
- Two component handle
- With hanging hole
- Contains also the most current 1/4" bits and sockets
- In display box

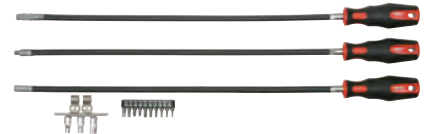

			kg
911.1180	16 pcs	ERGOTORQUE® screwdriver set	1.30
1 x		1/4"	
1 x		1/4"	
1 x		7 mm	
3 x		5 - 6 - 8 mm	
2 x		5.5 - 6.5 mm	
2 x		PH1 - PH2	
6 x		T10 - T15 - T20 - T25 - T27 - T30	

Hose clamp tension device

- For assembly and disassembly of hose clamps
- Easy to use
- Less space required
- Wear-resistant spindle drive
- Hand-wheel operation
- 6-point and 1/4" drive
- Chrome molybdenum



	Ø mm	Ø mm	Span width mm	Weight
115.0910	6-40	0-37	80	130
115.0911	6-65	0-62	105	160

Hose clamp gripping pliers

- Forged gripping jaws
- Serrated execution
- Size adjustment using the adjustment wheel
- Quick release lever
- Easy locking action
- For round and flat material
- Nickel plated
- Chrome vanadium



	Clamping range mm	L mm	Weight
115.1126	18-36	175.0	231
115.1127	18-54	230.0	420

Hose clamp gripping pliers set

- Forged gripping jaws
- Serrated execution
- Size adjustment using the adjustment wheel
- Quick release lever
- Easy locking action
- For round and flat material
- Nickel plated
- Chrome vanadium



	Weight
115.1125 2 pcs 175 - 230 mm	653

Hose clamp pliers

- Suitable for assembly and disassembly of spring clamps
- Optimal mounting due to special construction of jaws
- Includes locking mechanism and ratchet function
- PVC dipped handle
- Simple handling
- Special steel



	A mm	L mm	Weight
115.1181	0-55	260.0	380

Hose clamp pliers, angled

- Suitable for assembly and disassembly of spring clamps
- 90° angled
- Optimal mounting due to special construction of jaws
- With offset side attachment nuts
- Includes locking mechanism and ratchet function
- PVC dipped handle
- Simple handling
- Special steel



	A mm	L mm	Weight
115.1182	0-22	220.0	380

Hose clamp pliers, angled

- 45° angled head
- With variable jaws
- For difficult to reach clamps
- Includes locking mechanism
- With PVC dipped handle
- Chrome molybdenum

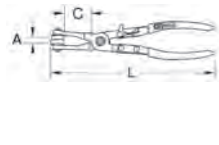

	A mm	C mm	L mm	Weight
115.1042	0-65	55.0	220.0	210

Hose clamp pliers, angled

- 90° angled head
- With moveable jaws
- For difficult to reach spring clamps
- Includes locking mechanism
- With PVC dipped handle
- Chrome molybdenum



	Ø mm	A mm	L mm	Weight
115.1198	18-53	5-43	210.0	400

Universal hose clamp pliers

- Universal crown profile
- For difficult to reach clamps
- With PVC dipped handle
- Includes locking mechanism
- Versatile usage
- Chrome molybdenum

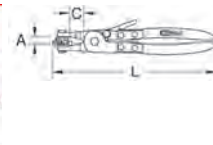

	A mm	C mm	L mm	Weight
115.1043	0-48.5	40.0	220.0	240

Hose clamp pliers

- Suitable for correct assembly and disassembly of spring clamps
- Turnable jaws
- Includes ratchet function
- Effortless opening and closing
- PVC dipped handle
- Special steel

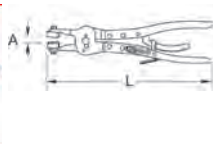

	A mm	L mm	Weight
115.1167	15-56	275.0	400

Hose clamp pliers

- PVC dipped handle
- For spring pipe clamps
- Includes locking mechanism and ratchet function
- Chrome molybdenum

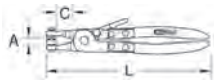

	A mm	C mm	L mm	
115.1046	0-45	37.0	220.0	230

Hose clamp pliers, angled

- Suitable for correct assembly and disassembly of spring clamps
- 110° angled
- Turnable jaws
- With locking device
- PVC dipped handle
- Special steel

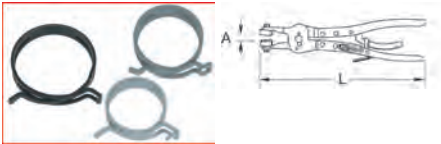

	A mm	L mm	
115.1173	6-58	250.0	400

Hose clamp pliers with double bowden cable

- PVC dipped handle
- For spring pipe clamps
- 600 mm bowden cable
- Adjustable length bowden cable
- Includes locking mechanism
- For difficult to reach clamps
- Special tool steel

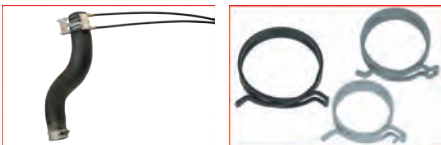

	Ø mm	L1 mm	L2 mm	
115.1065	0 - 70	270.0	600.0	115.1065-1 540

Hose clamp pliers, VAG

- Suitable for assembly or disassembly of spring clamps with reducing ends
- With PVC dipped handle
- With 600 mm Bowden cable
- Includes ratchet function, locking mechanism and loosening lever
- Internal spring
- For difficult to reach spring clamps
- Chrome molybdenum

Application range: VAG 2.0 TDI engines (BKD), especially suitably for hard to reach lower coolant hose

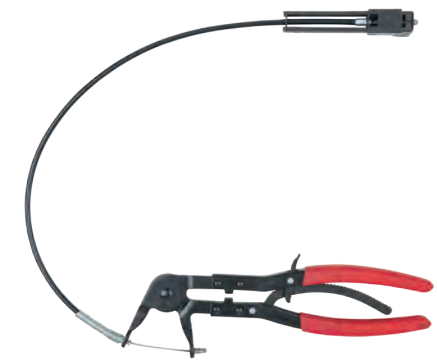

	Ø mm	L1 mm	L2 mm	
115.1169	0 - 60	260.0	600.0	500

Hose clamp pliers with bowden cable

- With PVC dipped handle
- For spring pipe clamps
- With 650 mm Bowden cable
- Includes ratchet function, locking mechanism and loosening lever
- Internal spring
- For difficult to reach spring clamps
- Chrome molybdenum

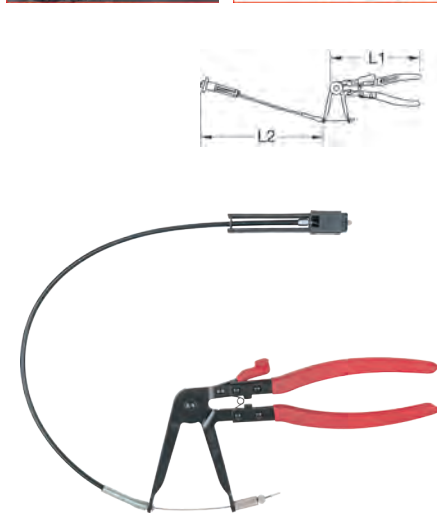

	Ø mm	L1 mm	L2 mm	
115.1168	0 - 70	260.0	650.0	500

Hose clamp pliers with bowden cable

- Ideally suited for opening and closing hose clamps
- Suitable for hard to reach self-tensioning spring clamps
- With 590 mm strengthened Bowden cable
- Includes locking mechanism
- Internal spring
- The torsion of the pliers is reduced with strong clamps
- With quick change system for Bowden cable replacement
- 2 component handle
- Strengthened steel

Application range: MUBEA and NORMA



	Ø mm	L1 mm	L2 mm	
115.0901	15 - 54	260.0	730.0	115.0902 500

Hose clamp pliers with bowden cable

- For self-tensioning hose clamps
- With locking mechanism
- In particular for fuel lines, cooling and washing water hoses
- With 650 mm Bowden cable
- With flat attachment for spring clamps with flat adjoining ends
- Opening and closing the clamps without damage to the hose also in hard to reach places
- Self-opening
- With PVC dipped handle
- Special steel

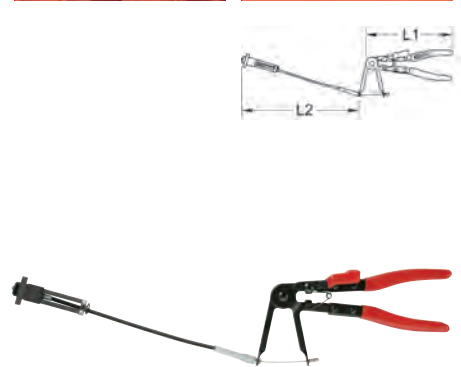

	Ø mm	L1 mm	L2 mm	
115.1041	0 - 60	200.0	650.0	115.1041-1 470

Spring band clamp pliers with gooseneck

- For actuation of self tensioning spring band clamps
- For cooling and heating systems
- Semi rigid, plastic coated gooseneck
- Convenient one handed operation in deep regions
- Fixing of the clamp by micro teeth
- Ideal for confined spaces
- Working head with raised grippers and wide opening
- Working head with slide guide and retraction spring
- With two component handle
- Chrome molybdenum

Application area: NORMA FBS, MUB FBS-STD, FBS-RSV, etc.



	Ø mm	L1 mm	L2 mm		g
115.1190	18-54	220.0	660.0	115.1190-1	620

Hose clamp pliers

- For the correct assembly and disassembly of spring clamps
- With 600 mm Bowden cable for hard to reach areas
- Step-less locking mechanism
- With quick-release lever
- Simple handling
- Special tool steel



	Ø mm	L1 mm	L2 mm	g
115.1189	0-50	210.0	600.0	330

Hose clamp pliers with swivel prism reception

- Suitable for the correct assembly and disassembly of Click, Click-R and Cobra clamps
- Also suitable for self-tensioning hose clamps with flat 3 pinch ends
- In particular for fuel lines, cooling and washing water hoses
- With swivel prism attachment
- Self-opening
- Surface nickel-plated
- Special steel

Application range: Volkswagen, Audi, Mercedes, Toyota etc.



	Clamping range mm	L mm	g
115.1188	8-18	210.0	200

Click hose clamp pliers, angled

- Suitable for the correct assembly and disassembly of Click, Click-R and Cobra clamps
- Also suitable for self-tensioning hose clamps with flat 3 pinch ends
- 90° angled head
- Effortless opening and closing
- Forged bite jaws
- With PVC dipped handle
- Special steel



	A mm	L mm	g
115.1179	0-18	180.0	160

Click hose clamp pliers, forged

- Suitable for the correct assembly and disassembly of Click, Click-R and Cobra clamps
- Also suitable for self-tensioning hose clamps with flat 3 pinch ends
- Re-usable V2A-clamps
- With PVC dipped handle
- With self-opening mechanism
- Chrome molybdenum



	A mm	C mm	L mm	g
115.1045	0-38	25.0	180.0	215

Click hose clamp pliers

- Suitable for the correct assembly and disassembly of Click, Click-R and Cobra clamps
- Also suitable for self-tensioning hose clamps with flat 3 pinch ends
- With PVC dipped handle
- Self-opening
- Chrome molybdenum

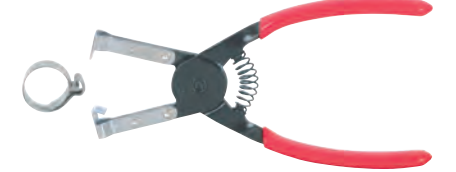

	A mm	C mm	L mm	g
115.1040	0-250	40.0	160.0	120

Hose clamp pliers

- PVC dipped handle
- For spring pipe clamps
- Includes locking mechanism and ratchet function
- Chrome molybdenum

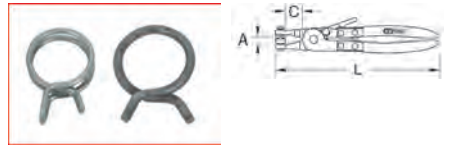

	A mm	C mm	L mm	g
115.1047	0-45	37.0	220.0	230

Automotive hose clamp pliers set

- Handle dip insulated
- Ideal for clamps low down in the engine
- Includes locking mechanism
- For self tensioning spring pipe clamps with 3 point mounting
- Self opening
- For opening and closing re/usable clic hose clamps, type Clic + Clic-R
- For difficult to reach clamps
- Special tool steel

Application area: For connecting and removing fuel, immersed ventilation, coolant, washer water and vacuum hoses, etc.

Application range: Volkswagen, Audi, Mercedes Benz, Toyota etc.



	A mm	C mm	L mm	g
115.1104	4 pcs	Automotive hose clamp pliers set		1.12

consists of:

115.1045	Hose clamp pliers (click type), 180mm	215
115.1042	Hose clamp pliers (recessed/slot), 220mm	210
115.1187	Hose clamp pliers with prism, 8-18mm	189
115.1065	Hose clamp pliers (dbl bowden cable), 600mm	540

Automotive hose clamp pliers set

- PVC dipped handle
- For opening and closing of cobra hose clamps
- Swivel pressed jaws
- Includes locking mechanism and ratchet function
- Self opening mechanism
- For the dismantling and assembly of hose clamps
- Includes bowden cable
- Chrome molybdenum



115.1055	7 pcs Automotive hose clamp pliers set	4.00

consists of:

115.1041	Hose clamp pliers (bowden cable), 650mm	470
115.1042	Hose clamp pliers (recessed/slot), 220mm	210
115.1043	Hose clamp pliers (crown profile), 220mm	240
115.1044	Hose pliers, 195mm	190
115.1045	Hose clamp pliers (click type), 180mm	215
115.1046	Hose clamp pliers (recessed/slot), 220mm	230
115.1047	Hose clamp pliers (dbl cross slot), 220mm	230

Fuel pipe pliers for compression coupling

- For correct opening of fuel pipe coupling
- Extra-flat jaws ends
- No damage to the compression coupling, fuel pipes and fuel hoses
- Quick and easy separation of the fuel pipes and fuel hoses
- Self-closing
- With PVC dipped handle
- Special steel

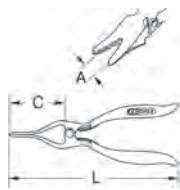

	A mm	L mm	C mm	
115.1044	0-30	195.0	70.0	190

Hose release pliers

- Suitable for releasing secured cooling hoses
- Securing screw for adjusting jaws
- Gentle on materials
- Lower power usage
- Simple operation
- Plastic handle
- Special steel



	Length mm	Ø mm	
115.1199	180.0	15-54	180

HOSE CLAMP TOOLS

Hose clamp set

- For easy clamping of flexible hose parts from 10.0 mm (3/8") to 45.0 mm (1.3/4")
- Continuous flow rate regulation, sensitive flow rate regulation or complete flow rate stop
- The hose is crimped over a wide area against the sturdy steel cross, damage to the hose is therefore prevented
- With revolving clamp wing from metal
- Ideal for maintenance work with petrol, oil, water and radiator antifreeze
- Protects from drips from petrol, oil, water and radiator antifreeze
- Ideally suitable for passenger cars, transporters, MPVs, commercial vehicles, tractors, agricultural and construction machinery and industrial uses
- Temperature resistant up to 160°
- Special steel



122.1200	4 pcs Hose clamp set	420

consists of:

122.1201	Hose clamp max. Ø 10 mm (3/8")	41
122.1202	Hose clamp max. Ø 15 mm (1/2")	46
122.1203	Hose clamp max. Ø 25 mm (1")	96
122.1204	Hose clamp max. Ø 45 mm (1.3/4")	237

Hose clamp pliers set

- For simple clamping of flexible for hoses from 15.9 mm (5/8") up to 60.0 mm (2.3/8")
- For stopping the flow
- The hose is a broad area squeezed against the stable support surface, damaging the hose is avoided
- Variable adjustment with locking function
- Ideal for maintenance work with gasoline, oil, water and antifreeze
- Protects against leakage of fuel, oil, water and antifreeze
- Ideal for use in passenger cars, vans and large vans, commercial vehicles, tractors, agricultural machinery, construction machinery and industrial applications
- Heat resistant up to 160° C
- Plastic



115.5050	3 pcs Hose clamp pliers set	370

consists of:

115.5052	Clamping pliers 150 mm for hoses up to Ø 15 mm	80
115.5053	Clamping pliers 180 mm for hoses up to Ø 30 mm	130
115.5054	Clamping pliers 250 mm for hoses up to Ø 60 mm	160

Hose clamp pliers set 90° angled

- For simple clamping of flexible for hoses from 15.9 mm (5/8") up to 60.0 mm (2.3/8")
- Angled design for use in confined spaces
- For stopping the flow
- The hose is a broad area squeezed against the stable support surface, damaging the hose is avoided
- Variable adjustment with locking function
- Ideal for maintenance work with gasoline, oil, water and antifreeze
- Protects against leakage of fuel, oil, water and antifreeze
- Ideal for use in passenger cars, vans and large vans, commercial vehicles, tractors, agricultural machinery, construction machinery and industrial applications
- Heat resistant up to 160° C
- Plastic



115.5055	3 pcs Hose clamp pliers set 90° angled	370

consists of:

		
115.5057	Clamping pliers 90°, Ø 15mm	55
115.5058	Clamping pliers 90°, Ø 30mm	95
115.5059	Clamping pliers 90°, Ø 60mm	130

ALLinONE Hose clamp pliers set

- Simple sealing of pipe lines, 4.75 mm (3/16") to 14.0 mm (9/16")
- Rotary magazine with 4 slots for the corresponding pipe size
- Ideal for maintenance work with gasoline, oil, water and antifreeze
- Protects against ingress of moisture and dirt
- Ideal for use in passenger cars, vans and large vans, commercial vehicles, tractors, agricultural machinery, construction machinery and industrial applications
- Special plastic

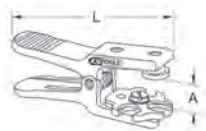

		Ø mm	A mm	L mm	
122.1295	2 pcs	4,75-14	38,0	120,0	149

consists of:

		
122.1296	ALLinONE Fluidstopper Ø 4,75 - 14 mm	60
122.1297	Replaceable plastic plugs for 122.1296 pipe stopper pliers	50

DRIP PANS

Oil drain pan 7.5 litres

- With three carry handles
- Safe and clean pouring with the self-contained overflow edge and spout
- Ideally suited to collecting different fluids
- Suitable for oil, chemicals, petrol, acid and anti-freeze fluid
- Also suitable for cleaning parts
- Practical, quick and friendly to the environment
- Shock-proof

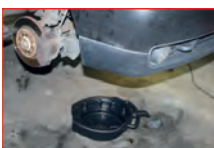

	Ø mm	H mm	
150.9359	385,0	130,0	620

Oil drain pan 8 litres

- With three carry handles
- Safe and clean pouring with the spout
- Ideally suited to collecting different fluids
- Suitable for oil, chemicals, petrol, acid and anti-freeze fluid
- Also suitable for cleaning parts
- Practical, quick and friendly to the environment
- Screwed connection with rubber seal for safe transport
- Shock-proof



	B mm	H mm	L mm	
150.9357	340,0	120,0	600,0	1,06

Oil drain pan 17 litres

- With three carry handles
- Safe and clean pouring with the self-contained overflow edge and spout
- Ideally suited to collecting different fluids
- Suitable for oil, chemicals, petrol, acid and anti-freeze fluid
- Also suitable for cleaning parts
- Practical, quick and friendly to the environment
- Shock-proof



	Ø mm	H mm	
150.9360	445,0	145,0	1,16

Oil drain pan 17 litres

- With three carry handles
- Safe and clean pouring with the self-contained overflow edge and spout
- Ideally suited to collecting different fluids
- Suitable for oil, chemicals, petrol, acid and anti-freeze fluid
- Also suitable for cleaning parts
- Practical, quick and friendly to the environment
- Shock-proof

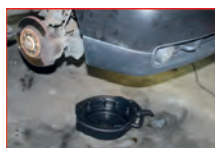

	Ø mm	H mm	
150.9361	445,0	145,0	1,16

Mobile oil drain pan, 30 litres, extra flat with castors

- With five carry handles
- 12.0 cm high, extra flat edges
- Safe and clean pouring with the closed contained and spout
- Ideally suited to collecting different fluids
- Suitable for oil, chemicals, petrol, acid and anti-freeze fluid
- Also suitable for cleaning parts
- With four steerable castors
- Practical, quick and friendly to the environment
- Includes removable sieve
- Screwed connection with rubber seal for safe transport
- Shock-proof



	B mm	H mm	L mm	
150.9354	600,0	120,0	850,0	5,60



Oil drain pan 55 litres, extra flat

- With four carry handles
- 11.0 cm high, extra flat edges
- Safe and clean pouring with the self-contained overflow edge and spout
- Ideally suited to collecting different fluids
- Suitable for oil, chemicals, petrol, acid and anti-freeze fluid
- Also suitable for cleaning parts
- Practical, quick and friendly to the environment
- Shock-proof
- Polyethylene



	L mm	B mm	H mm	
150.9358	1030,0	724,0	110,0	6,80

1
2
3
4
5
6
7
8
9
10
11
12
13
14
15
16
17
18
19
20
21
22
23
24
25
26

MEASURING BEAKER, JUG AND FUNNEL

Measuring cup set

- Configuration of practical measuring cup sizes
- Versatile application possibilities
- Transparent
- Break-proof
- Red primed scale division
- Resistant to oil, petrol and acid
- With handle and spout
- PE (polyethylene)

Scales: L/ml, cups, Oz, quart



Product Code	Quantity	Capacity	Weight (g)
150.9205	3 pcs	250 - 500 - 1.000 ml	227

Oil can with flexible outlet spout

- For a wide range of uses
- Flexible, funnel-shaped spout allows for a clean drainage
- Suitable for oil, chemicals, petrol, acid, anti-freeze fluid and non-acidic fluids
- Break-resistant
- Steady
- Graduated scale
- With practical carry handle
- Special plastic



Product Code	Quantity	Spout	Weight (g)
150.9234	1	150.9236	150
150.9235	2	150.9236	250

Water can

- For a wide range of uses
- Break-resistant
- With 2 carry handles
- Pouring spout enables clean emptying
- Suitable for water and coolant fluid
- Special plastic



Product Code	Quantity	Weight (g)
150.9239	9	920

Funnel set

- Configuration of practical funnel sizes
- Versatile application possibilities
- Red
- Break-proof
- Resistant to oil, petrol and acid
- Grip strap for convenient use
- HDPE (high density polyethylene)



Product Code	Quantity	Dimensions	Weight (g)
150.9240	5 pcs	Ø 50 - Ø 75 - Ø 95 - Ø 115 - Ø 150 mm	251

Universal funnel set

- Special flexible funnel for hard-to-reach places
- For a wide range of uses
- With bayonet connection and seal
- Direct connection to the oil fill opening
- No more lengthy and time-consuming pouring
- Includes clear hose with sealing plug on the end of the hose
- Bottle with handle for comfortable use
- Reduces loss and dirtying of oily engines
- Special plastic



Product Code	Quantity	Tube Ø (mm)	Spout	Funnel Ø (mm)	Tube length (mm)	Weight (g)
150.9230	3 pcs	14x16	1	160	400	240



TRANSFER PUMPS

Mini transfer pump

- Ideal aid for transferring in emergencies
- Suitable for battery acid, fuels, oils and distilled water
- The hoses are attached to the balloon holder using supplied hose clamps
- Acid-resistant
- Special plastic



Product Code	Tube inner Ø (mm)	Tube length (mm)	Weight (g)
150.1665	8.0	2 x 900	320

Transfer pump

- Ideal aid for easy transferring and pumping
- Suitable for battery acid, fuels, oils and distilled water
- Acid-resistant
- With high quality pump body and reinforced pump handle
- Special plastic



Product Code	Tube inner Ø (mm)	Tube length (mm)	Weight (g)
150.1660	12.0	2 x 1.300	465

Syringe for fluid change 0.2 l

- Ideal tool for decanting, removing or dosing liquids to transmissions, power steering, hydraulics, engines, etc.
- Suitable for fuel oil, water and antifreeze
- Fine dosing
- Overflowing material can be pumped back problem-free
- Includes rubber hose
- Robust metallic design



		Tube inner Ø mm	Hose external Ø mm	Tube length mm	Housing length mm	
150.1684	0.2	8	10	290	290	365

Syringe for fluid change 0.2 l

- Ideal tool for decanting, removing or dosing liquids to transmissions, engines (sic) power steering, hydraulics, engines, etc.
- Suitable for fuel oil, water and antifreeze
- Fine dosing
- Overflowing material can be pumped back problem-free
- Includes rubber hose with flow stop cap
- Robust PP design



		Tube inner Ø mm	Hose external Ø mm	Tube length mm	Housing length mm	
150.9221	0.2	6	8	210	210	245

Syringe for fluid change 1.5 l

- Ideal tool for decanting, removing or dosing liquids to transmissions, engines (sic) power steering, hydraulics, engines, etc.
- Suitable for fuel oil, water and antifreeze
- Fine dosing
- Overflowing material can be pumped back problem-free
- Includes rubber hose with flow stop cap
- Robust PP design



		Tube inner Ø mm	Hose external Ø mm	Tube length mm	Housing length mm	
150.9222	1.5	14	16	320	320	900

2 direction suction and filling hand pump

- Ideal for bleeding and filling of fluids
- With ball valve to select between suction and pressure
- Suck and press with every way
- Wear-resistant and temperature resistant
- For difficult to reach openings
- With 2 tubes
- Suction tube clear Ø l x E: 10x16 mm, length 600 mm
- Pressure tube fabric-reinforced Ø l x E: 16x21mm, length 600 mm
- For brake fluid, motor / transmission oil, petrol, diesel, fuel oils, spirit, petroleum, antifreeze etc.
- Robust aluminum piping

Application range: Vehicle/trucks workshops, land and construction machines, municipally and forestry technology, etc.



	Stroke mm	Content	L mm	Ø mm	
150.9255	208.0	256	808.0	40	662
150.9256	255.0	720	855.0	60	884

Dispense hand pump PVC, 1,000 ml with tube

- For the controlled bleeding and filling of fluids
- Exact dosage per scale
- High suction
- For difficult to reach openings
- For brake fluid, motor / transmission oil, petrol, diesel, fuel oils, spirit, petroleum, antifreeze etc.
- Fabric-reinforced PVC tube
- PVC cylinder

Application range: Vehicle/trucks workshops, land and construction machines, municipally and forestry technology, etc.



Technical data:
 Lift volume: 1,000 ml
 Stroke: 420.0 mm
 Scale division: 25 ml
 Connection thread: M15x1.5IG

	Ø mm	L mm	
150.9250	60	465.0	931

PVC Tube

- Fabric-reinforced
- For 150.9250



	L mm	Inner Ø mm	Outer Ø mm	
150.9253	600.0	10.0	16.0	110

PVC Tube with curved outlet pipe

- For difficult to reach openings
- With wing nut and sealing for locking
- With external thread M15 x 1.5
- Robust, curved aluminum piping
- Fabric-reinforced
- Ideal for use with KS dispense hand pump 150.9250

Application range: For brake fluid, motor / transmission oil, petrol, diesel, fuel oils, spirit, petroleum, antifreeze etc.



	L mm	Ø mm	Bend radius	
150.9252	750.0	10	120°	125

Metal pipe, flexible with outlet head

- For difficult to reach openings
- With wing nut and sealing for locking
- With external thread M15 x 1.5
- Durable, flexible steel pipe
- Ideal for use with KS dispense hand pump 150.9250

Application range: For brake fluid, motor / transmission oil, petrol, diesel, fuel oils, spirit, petroleum, antifreeze etc.



	L mm	Ø mm	
150.9251	250.0	10	82

1
2
3
4
5
6
7
8
9
10
11
12
13
14
15
16
17
18
19
20
21
22
23
24
25
26