

Hydraulik-Werkzeuge

Hydraulic tools

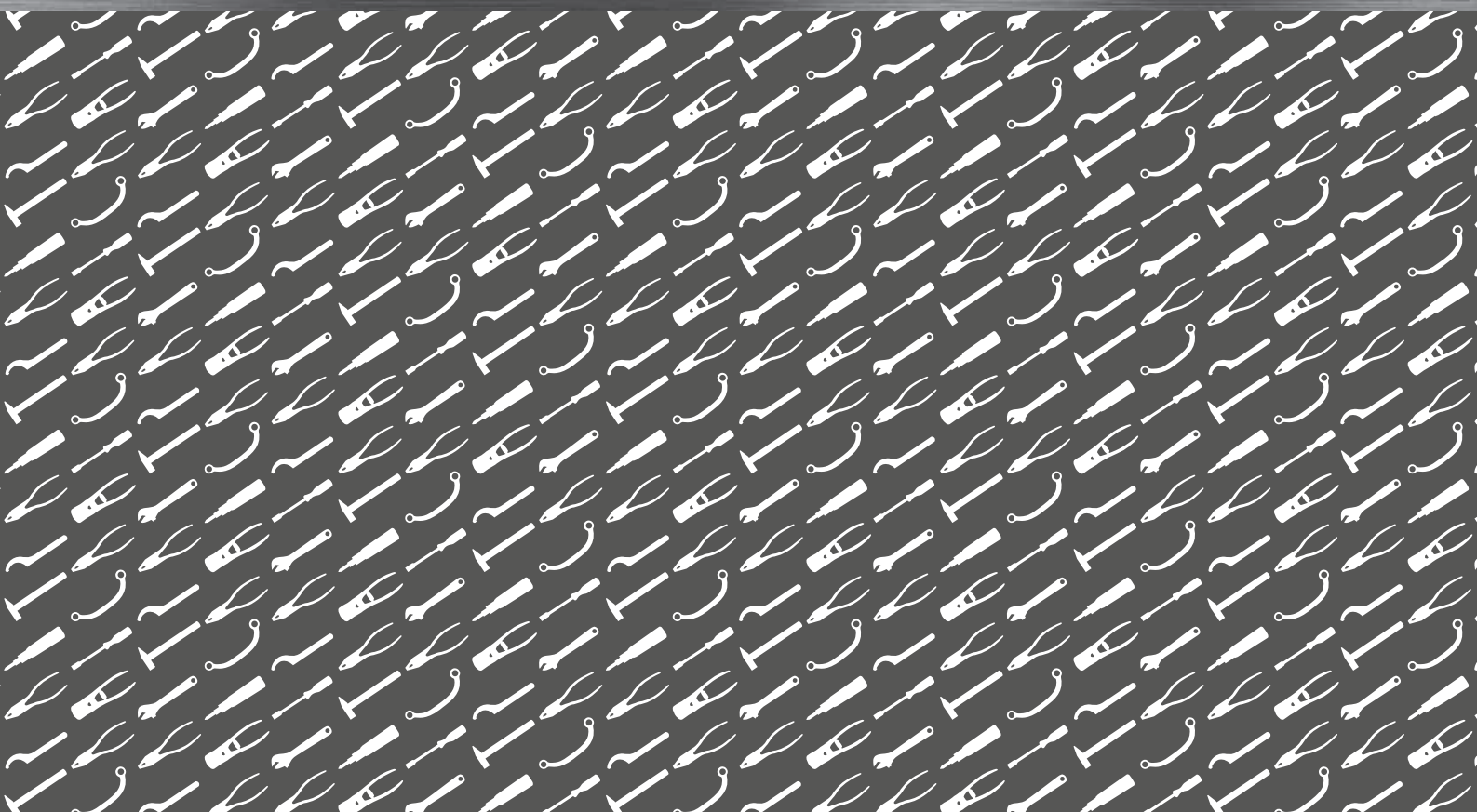

Hydraulische Werkzeuge

Einsatzgebiete:

- Kraftwerke
- Chemische Industrie
- Bergbau / Ölindustrie
- Maschinenbau
- Schiffbau
- Anlagenbau
- Stahlbau
- Kunststoffindustrie
- Lebensmittelindustrie

Vorteile:

- höchste Drehmomente (-100.000 Nm)
- hohe Genauigkeit ($\pm 3\%$ - BOLTMAX compact)
- Arbeitssicherheit (Schlagschlüssel sind überflüssig)
- Flexibilität
(wechselbare Kassetten, Sonderanfertigungen*)
- kompakte Bauform
(extrem kleine Kopfradien RK - BOLTMAX compact)
- geringes Gewicht (bis zu 1450 Nm/KG - RSL30SDS)
- hohe Arbeitsgeschwindigkeit (BOLTMAXxt)

Hydraulic tools

Fields of application:

- power generating industry
- chemical industry
- mining/oil exploration
- mechanical engineering
- ship yards
- construction/ship building industry
- steel construction
- plastic industry
- food industry

Advantages:

- highest torques (-100.000 Nm)
- high accuracy ($\pm 3\%$ - BOLTMAX compact)
- working safety (replaces slugging spanners)
- flexibility
(changeable cassettes, specially designed accessory*)
- compact construction (extremely small head radius RK - BOLTMAX compact)
- low weight (up to 1450 Nm/KG - RSL30SDS)
- quick mounting (BOLTMAXxt)

Typen Types available	
BOLTMAX <i>compact</i>	Kompaktschrauber für Wechselkassetten compact hydraulic wrench with changeable cassettes
BOLTMAX <i>classic</i>	Vierkantschrauber in bewährter Qualität hydraulic wrench with fix square drive in approved quality
BOLTMAX <i>custom</i>	Spezialfertigung nach Kundenwunsch* specially designed parts*
BOLTMAX <i>tension</i>	Hydraulische Bolzenlängung hydraulic bolt tensioners
BOLTMAX <i>xt</i>	Montagesystem für Plattenwärmetauscher mounting system for heat exchangers



* Bitte sprechen Sie unser Beraterteam an

* please, ask our customer consultants

BOLTMAX

compact

Der Kompakt-Hydraulikschrauber aus der BOLTMAX Familie

Boltmax ist:

sicher

- genügt höchsten Sicherheitsanforderungen
- alle beweglichen Teile im Gehäuse, somit keine Verletzungsgefahr

schnell

- schnelles Arbeiten durch langen Arbeitshub ohne Abstriche in der Genauigkeit zu machen
- hohe Produktivität und geringe Ausfallzeiten durch ein optimiertes und klemmfreies Ratschensystem

leicht

- wurde konstruiert und berechnet mit modernsten Methoden (CAD/ FEM)
- optimiertes Verhältnis von Gewicht und Drehmoment

präzise

- Genauigkeit $\pm 3\%$

flexibel

- umfassendes Zubehörprogramm
- sowohl Vierkantkassetten als auch Ringschlüsselkassetten
- Einsätze mit direkter Kerbverzahnung und spezielle Abstützungen im System integriert
- kundenspezifische Sonderfertigungen auf Anfrage

dauerhaft

- nur wenig sorgfältig konzeptionierte Einzelkomponenten = hohe Qualität

kompakt

- extrem kompaktes Design – speziell für beengte Verhältnisse
- minimierte Kopfradien (R/K)

The compact hydraulic torque wrench from the BOLTMAX family

Boltmax shows the following characteristics:

safe

- complies with highest security requirements
- all movable parts are into the casing, thus no risk of injury

quick

- quick and safe work on account of the long working stroke without compromise on the accuracy
- optimized and jamming ratcheting system minimizes the downtime of torque wrench and thus increases productivity

low weight

- has been designed and calculated by the latest Methods (CAD/FEM)
- an optimized ratio between weight and torque value

precise

- tolerance of $\pm 3\%$ only

flexible

- a wide range of accessory tools
- can be fitted with a square drive cassette as well as A ring cassette
- Sockets with direct tothing and special support Arms are deliverable as well
- Special versions on request

solid and long lasting

- only a few carefully designed components = high quality

compact

- minimised dimensions - specifically for tight spaces
- minimized head radius (R/K)

BOLTMAX 200 - 38500 Nm

compact

RSLSDS

Werkzeugsatz bestehend aus:

- Grundwerkzeug BOLTMAX compact RS
- Vierkantkassette BOLTMAX compact S
- Abstützung BOLTMAX compact RSLA
- Lieferung ohne Swivel Kupplung

RSLSDS

Tool set consisting of:

- Basic tool BOLTMAX compact RS
- square cassette BOLTMAX compact S
- reaction anchor BOLTMAX compact RSLA
- delivery without swivel connector

Artikel-Nr. Order-No.	Ident-Nr. Ident-No.	Nm _{max}	P _{max} [bar]	Ausgang Output	L	B	H	R _K	
RSL2SDS	74000	1937	700	20 (3/4")	160	114	65	23,9	3000
RSL4SDS	74020	4237	700	25 (1")	196	142	80	31,8	4900
RSL6SDS	77430	7325	700	40 (1 1/2")	235	164	100	38,6	8000
RSL8SDS	74040	10813	700	40 (1 1/2")	279	169	115	38,6	9900
RSL14SDS	74060	15342	700	40 (1 1/2")	286	202	125	47,8	13300
RSL20SDS	74065	26821	700	63 (2 1/2")	336	241	160	63,5	22100
RSL30SDS	74080	38516	700	63 (2 1/2")	385	263	165	63,5	26400

Hydraulikpreise auf Anfrage „Sonderpreisliste“

Price on request (special pricelist)

RSL2SDS - RSL30SDS

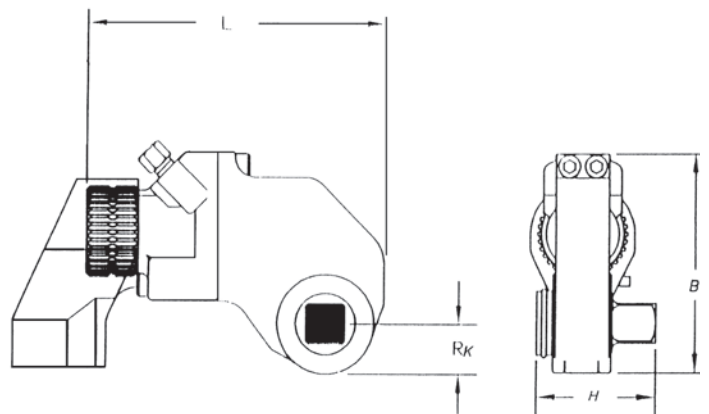

RSL4 + RSL4i/60
RSL4 + RSL4i/60

Einsätze mit direkter Kerbverzahnung für BOLTMAX compact RSLSDS

Diese Steckschlüsseinsätze werden, anstelle des Abtriebsvierkant, direkt in die Verzahnung des Schraubwerkzeuges eingesetzt.

- geringe Bauhöhe
- Verringerung des Biegemoments

Sockets with direct tothing for BOLTMAX compact RSLSDS

These sockets are directly inserted into the tothing of hydraulic tools (instead of the square drive)

- smaller dimensions
- reduction of bending load

RSL2

RSL2

Artikel-Nr. Order-No.	Ident-Nr. Ident-No.		$\overline{\text{mm}}$	\varnothing
RSL2/22	76988		22	36,5
RSL2/24	76989		24	39,0
RSL2/25	76990		27	43,0
RSL2/30	76991		30	47,0
RSL2/32	76992		32	50,0
RSL2/36	76993		36	57,0
RSL2/41	76994		41	64,0
RSL2/46	76995		46	71,0

RSL2



RSL4

RSL4

Artikel-Nr. Order-No.	Ident-Nr. Ident-No.		$\overline{\text{mm}}$	\varnothing
RSL4/27	76996		27	43,0
RSL4/30	76997		30	47,5
RSL4/32	76998		32	50,0
RSL4/36	76999		36	56,0
RSL4/41	77000		41	64,0
RSL4/46	77001		46	71,0
RSL4/50	77002		50	76,0
RSL4/55	77003		55	80,0

RSL4



RSL6

RSL6

Artikel-Nr. Order-No.	Ident-Nr. Ident-No.		$\overline{\text{mm}}$	\varnothing
RSL6/46	77050		46	71
RSL6/50	77051		50	76
RSL6/55	77052		55	82
RSL6/60	77053		60	89
RSL6/65	77055		65	95
RSL6/70	77056		70	100
RSL6/75	77057		75	106
RSL6/80	77058		80	114

RSL6



RSL8

RSL8

Artikel-Nr. Order-No.	Ident-Nr. Ident-No.		$\overline{\text{mm}}$	\varnothing
RSL8/55	77009		55	82,0
RSL8/60	77010		60	89,0
RSL8/65	77011		65	95,0
RSL8/70	77012		70	100,0
RSL8/75	77013		75	106,0
RSL8/80	77015		80	114,0
RSL8/85	77016		85	120,0
RSL8/90	77017		90	126,0
RSL8/95	77018		95	132,0

RSL8



RSL14

RSL14

Artikel-Nr. Order-No.	Ident-Nr. Ident-No.		$\overline{\text{mm}}$	\varnothing
RSL4/65	77019		65	95
RSL4/70	77020		70	100
RSL4/75	77021		75	111
RSL4/80	77022		80	117
RSL4/85	77023		85	124
RSL4/90	77025		90	130
RSL4/95	77026		95	139
RSL4/100	77030		100	147
RSL4/105	77031		105	152
RSL4/110	77032		110	159
RSL4/115	77033		115	166

RSL14



RSL20

RSL20

Artikel-Nr. Order-No.	Ident-Nr. Ident-No.		$\overline{\text{mm}}$	\varnothing
RSL20/80	77080		80	117
RSL20/85	77081		85	124
RSL20/90	77082		90	130
RSL20/95	77083		95	139
RSL20/100	77085		100	147
RSL20/105	77087		105	152
RSL20/110	77088		110	159
RSL20/115	77089		115	166
RSL20/120	77090		120	172
RSL20/125	77091		125	178
RSL20/130	77092		130	185

RSL20



RSL30

RSL30

Artikel-Nr. Order-No.	Ident-Nr. Ident-No.		$\overline{\text{mm}}$	\varnothing
RSL30/80	77035		80	117
RSL30/85	77036		85	124
RSL30/90	77039		90	130
RSL30/95	77040		95	139
RSL30/100	77041		100	147
RSL30/105	77042		105	152
RSL30/110	77043		110	159
RSL30/115	77045		115	166
RSL30/120	77046		120	172
RSL30/125	77047		125	178
RSL30/130	77048		130	185

RSL30



Alle Einsätze sind auch für Innensechskant-Schrauben
lieferbar

auf Anfrage

All inserts are also available for hexagon sockets
screws

on request

RSL HEX



BOLTMAX 200 - 38500 Nm *compact*

Basisgerät
incl. HD-Anschlüssen

basic tool
with HD-connectors

Artikel-Nr. Order-No.	Ident-Nr. Ident-No.		Nm _{max}	P _{max} [bar]	
RSL2	74001		1960	700	1800
RSL4	74021		4195	700	2800
RSL6	74031		7325	700	3900
RSL8	74041		10825	700	5400
RSL14	74061		15360	700	5800
RSL20	77470		26821	700	8300
RSL30	74081		38560	700	9700

RSL



Abstützungen
360° drehbar, extrem leicht

Reaction bars
1360° rotatable, light weight

Artikel-Nr. Order-No.	Ident-Nr. Ident-No.		
RSLA2	74004		200
RSLA4	74024		600
RSLA6	74034		1400
RSLA8	74044		1600
RSLA14	74064		1700
RSLA20	77481		3800
RSLA30	77482		5700

RSLA



Vierkant-Kassetten

Square cassettes for

Artikel-Nr. Order-No.	Ident-Nr. Ident-No.		Ausgang Output		R _K	
RSL S2	74003		20 (3/4")		23,9	1200
RSL S4	74023		25 (1")		31,8	2200
RSL S6	74033		40 (1/2")		38,6	4100
RSL S8	74043		40 (1 1/2")		38,6	5100
RSL S14	74063		40 (1 1/2")		47,8	7500
RSL S20	77483		63 (2 1/2")		63,5	14200
RSL S30	74083		63 (2 1/2")		63,5	16700

RSL S

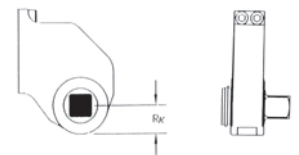

BOLTMAX 200 - 38500 Nm

compact

Ringschlüsselkassetten für BOLTMAX compact

Hexagon heads to be used with BOLTMAX compact

RSL2H

RSL2H

Artikel-Nr. Order-No.	Ident-Nr. Ident-No.		↕ mm	RI	W
RSL2H22	74501		22	22,4	32
RSL2H24	74005		24	23,4	32
RSL2H27	74006		27	24,1	32
RSL2H30	74007		30	26,1	32
RSL2H32	74008		32	27,0	32
RSL2H36	74009		36	29,1	32
RSL2H41	74010		41	33,4	32
RSL2H46	74011		46	35,5	32
RSL2H50	74012		50	37,7	32
RSL2H55	74013		55	40,2	32
RSL2H60	74014		60	43,1	32

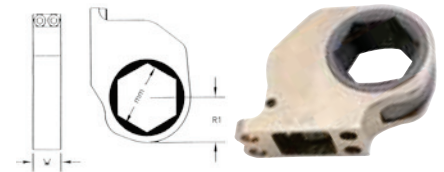

RSL2H

RSL4H

RSL4H

Artikel-Nr. Order-No.	Ident-Nr. Ident-No.		↕ mm	RI	W
RSL4H36	74502		36	28,7	35
RSL4H41	74503		41	32,6	35
RSL4H46	74025		46	36,6	35
RSL4H50	74026		50	39,8	35
RSL4H55	74027		55	43,8	35
RSL4H60	74028		60	47,8	35
RSL4H65	74029		65	51,8	35
RSL4H70	74030		70	55,7	35

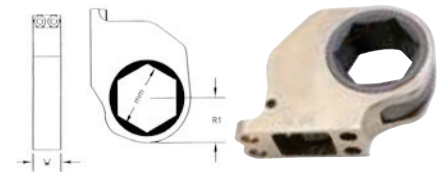

RSL4H

RSL6H

RSL6H

Artikel-Nr. Order-No.	Ident-Nr. Ident-No.		↕ mm	RI	W
RSL6H50	77059		50	40,9	45
RSL6H55	77060		55	43,4	45
RSL6H60	77061		60	47,5	45
RSL6H65	77062		65	51,0	45
RSL6H70	77063		70	54,9	45
RSL6H75	77065		75	56,9	45
RSL6H80	77066		80	57,4	45

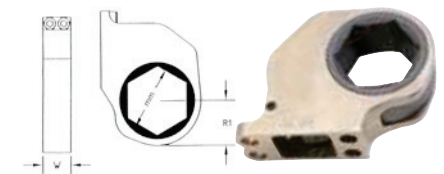

RSL6H

RSL8H

RSL8H

Artikel-Nr. Order-No.	Ident-Nr. Ident-No.		↕ mm	RI	W
RSL8H55	74505		55	43,4	58
RSL8H60	74045		60	47,5	58
RSL8H65	74046		65	51,1	58
RSL8H70	74047		70	54,9	58
RSL8H75	74048		75	56,9	58
RSL8H80	74049		80	57,4	58

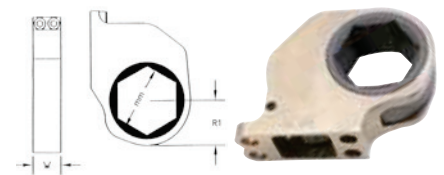

RSL8H

BOLTMAX 200 - 38500 Nm *compact*

RSL14H

RSL14H

RSL14H

Artikel-Nr. Order-No.	Ident-Nr. Ident-No.		↕ mm	RI	W
RSL14H70	74062		70	55,7	64
RSL14H75	74506		75	56,5	64
RSL14H80	74507		80	60,2	64
RSL14H85	74066		85	64,0	64
RSL14H90	74067		90	67,8	64
RSL14H95	74068		95	71,5	64
RSL14H100	74069		100	75,3	64
RSL14H105	74070		105	79,1	64
RSL14H110	74071		110	82,8	64
RSL14H115	74072		115	86,6	64

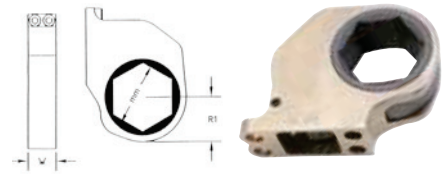

RSL20H

RSL20H

RSL20H

Artikel-Nr. Order-No.	Ident-Nr. Ident-No.		↕ mm	RI	W
RSL20H80	77471		80	62,2	70
RSL20H85	77472		85	70,4	70
RSL20H90	77473		90	74,9	70
RSL20H95	77475		95	74,9	70
RSL20H100	77476		100	83,8	70
RSL20H105	77477		105	83,8	70
RSL20H110	77478		110	87,4	70
RSL20H115	77479		115	87,4	70



RSL30H

RSL30H

RSL30H

Artikel-Nr. Order-No.	Ident-Nr. Ident-No.		↕ mm	RI	W
RSL30H80	74508		80	65,0	76,0
RSL30H85	74084		85	65,0	76,0
RSL30H90	74085		90	74,2	76,0
RSL30H95	74086		95	74,2	76,0
RSL30H100	74087		100	83,6	76,0
RSL30H105	74088		105	83,6	76,0
RSL30H110	74089		110	87,1	76,0
RSL30H115	74090		115	87,1	76,0
RSL30H120	74091		120	92,7	76,0
RSL30H130	74093		130	96,3	76,0
RSL30H135	74094		135	96,3	76,0
RSL30H140	74095		140	102,9	76,0
RSL30H145	74096		145	102,9	76,0
RSL30H150	74097		150	107,2	76,0
RSL30H155	74098		155	107,2	76,0



Ringschlüsselkassette im Einsatz
Hexagonhead in use



Kassette und Basisgerät
Cassettes and basic tool

BOLTMAX

classic

Der bewährte Hydraulikschrauber aus der Boltmax Familie

- Der Ursprung des gesamten Boltmax Systems
- Zuverlässigkeit und Präzision seit über 20 Jahren
- Verschraubungen in einem großen Drehmomentbereich (300 - 100.000 Nm)
- Der Schrauber mit modularem Aufbau
- Ein System mit vielen Möglichkeiten

Well approved hydraulic torque wrench out of the BOLTMAX family

- original tools of the whole BOLTMAX system
- reliability and precision for more than 20 years
- tightening/loosening in a huge variety of torques (300 - 100.00 Nm)
- a torque tool with modular construction
- a system with many possibilities



Boltmax classic BM 100.000 im Einsatz
Boltmax classic BM 100.000 in use

BOLTMAX

100-100000 Nm

classic

Modular aufgebautes, hydraulisches Verschraubungswerkzeug

- spezialverzahnte Ratsche
- wechselbarer Vierkant
- incl. Drehwinkelskala

modular built-up hydraulic tightening tool

- specially toothed ratchet
- changeable square drive
- incl. torque angle measuring scale

Artikel-Nr. Order-No.	Ident-Nr. Ident-No.		Nm _{max}	P _{max} [bar]	Ausgang Output	L	B	H	R _K	
BM3000	76908		3000	700	25 (1")	289	156	88	37	6900
BM5000	77137		5000	700	40 (1 1/2")	291	158	99	39	7000
BM6250	77157		6500	700	40 (1 1/2")	291	158	99	39	7200
BM10000	78037		10000	700	40 (1 1/2")	342	203	108	57	12900
BM12500	78039		12500	700	40 (1 1/2")	347	208	108	57	13200
BM20000	78937		20000	700	63 (2 1/2")	382	238	150	63	22900
BM25000	78957		25000	700	63 (2 1/2")	402	243	150	68	24500
BM32000	78997		32000	700	63 (2 1/2")	402	243	152	68	26000
BM50000	79538		50000	700	90 (3 1/2")	546	303	212	85	60000
BM100000	79650		100000	700	90 (3 1/2")	715	380	237	120	120000

Abstützstücke

Ermöglichen das Abstützen auf einer „Nachbarschraube“ (z.B. am Blindflansch)

BM3000

Artikel-Nr. Order-No.	Ident-Nr. Ident-No.		Ausgang Output		L
BMA3/1	77044		25 (1")		110
BMA3/2	77064		25 (1")		140

BM5000-6250

Artikel-Nr. Order-No.	Ident-Nr. Ident-No.		Ausgang Output		L
BMA5/1	77594		40 (1 1/2")		110
BMA5/2	77604		40 (1 1/2")		140

BM10000-12500

Artikel-Nr. Order-No.	Ident-Nr. Ident-No.		Ausgang Output		L
BMA10/1	78484		40 (1 1/2")		110
BMA10/2	78494		40 (1 1/2")		140
BMA10/3	78504		40 (1 1/2")		170
BMA10/4	78514		40 (1 1/2")		250

BM20000-25000

Artikel-Nr. Order-No.	Ident-Nr. Ident-No.		Ausgang Output		L
BMA20/1	79404		63 (2 1/2")		170

Reaction bars

facilitates to use a „neighbour bolt“ as counterstay (e.g. at blind flange)

BM3000

BM5000-6250

BM10000-12500

BM20000-25000

BM

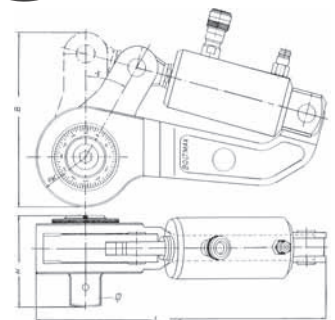

700 bar

HD-Hydraulikschlauch

- ölfüllt und entlüftet
- incl. HD-Kupplungen
- mit Knickschutz

HD-hydraulic hose

- oil filled and free from air
- incl. HD couplings
- with bending protector

Artikel-Nr. Order-No.	Ident-Nr. Ident-No.		L	
HD2	77897		2000	1000
HD3	77777		3000	1400
HD5	77987		5000	1800
HD10	77997		10000	3100
HD20	78007		20000	5800

HD



700 bar

Elektro-Hydraulikpumpe / Pumpen für Hydraulikschraubler

- dreistufige Axialkolbenpumpe
- E-motor
- 2800 min-1
- regelbares Druckbegrenzungsventil
- Manometer Ø 100 mm
- incl. Kupplungen, Ölfüllung und Fernsteuerung (5m)

Electro hydraulic pump / Pumps for hydraulic tightening tools

- three step axial reciprocating pump
- electro motor
- 2800 min-1
- adjustable pressure relief valve
- manometer diam. Ø 100 mm
- incl. couplings, oil filling and remote control (5m)

Artikel-Nr. Order-No.	Ident-Nr. Ident-No.		Förderleistung Volume	Tank [L] Tank [L]	L	B	H	V	
HE025	77903		1) 75 bar: 3,2 l 2) 200 bar: 0,9 l 3) 700 bar: 0,4 l	2,5	360	230	400	230	15000
HE055	77902		1) 75 bar: 6,5 l 2) 200 bar: 1,8 l 3) 700 bar: 0,7 l	4,0	400	280	400	230	25000
HE110	77901		1) 75 bar: 8,5 l 2) 200 bar: 3,4 l 3) 700 bar: 1,3 l	4,0	460	300	440	400	30000

HE

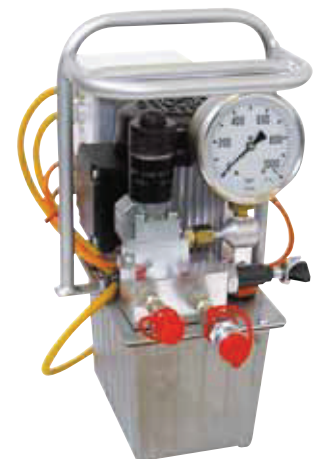

700 bar

Hand-Hydraulikpumpe für Hydraulikschrauber

- zweistufige Handpumpe
- Manometer 100 mm
- incl. Kupplungen und Ölfüllung

Manual hydraulic pump

- two step manual pump
- manometer diam. 100 mm
- incl. couplings and oil filling

Artikel-Nr. Order-No.	Ident-Nr. Ident-No.		Förderleistung [ccm] Volume [ccm]	Tank [L] Tank [L]	L	B	H	
BMPH262	77928		1) 70 bar: 32 2) 700 bar: 3,0	1,9	575	120	170	8000

BMPH 262

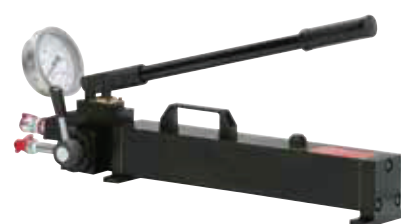

700 bar

Luft-Hydraulikpumpe

- zweistufige Axialkolbenpumpe
- Luftmotor, 1,1 kW
(Betriebsdruck 5 - 10 bar - 16 l/sec)
- P3000 min-1
- regelbares Druckbegrenzungsventil
- Manometer Ø 100 mm
- incl. Wartungseinheit, Kupplungen, Ölfüllung und Fernsteuerung (5m)

Air hydraulic pump

- two step axial reciprocating pump
- air motor, 1,1 kW
(working pressure 5 - 10 bar - 16 l/sec)
- 3000 min-1
- adjustable pressure relief valve
- manometer diam. 100 mm
- incl. service unit, couplings, oil filling and remote control (5m)

Artikel-Nr. Order-No.	Ident-Nr. Ident-No.		Förderleistung [l/min] Volume [l/min]	Tank [L] Tank [L]	L	B	H	
BMPL32	77907		1) 70 bar: 5,5 2) 700 bar: 0,5	6,5	360	410	450	22000

BMPL 32



1600 bar

Pumpe für BOLTMAX tension

Hand-Hydraulikpumpe

- zweistufige Handpumpe
- Manometer 100 mm
- incl. Kupplungen und Ölfüllung

Pumps for BOLTMAX tension

Manual hydraulic pump

- two step manual pump
- manometer diam. 100 mm
- incl. couplings and oil filling

Artikel-Nr. Order-No.	Ident-Nr. Ident-No.	Förderleistung [ccm] Volume [ccm]	Tank [L] Tank [L]	L	B	H	
BMPML16216	77431	1) 20 bar: 32 2) 1600 bar: 1,6	1,9	575	120	170	8000

BMPML16216



1600 bar

HD-Hydraulikschläuche

- ölgefüllt und entlüftet
- incl. HD-Kupplungen
- mit Knickschutz

HD-hydraulic hoses

- oil filled and free from air
- incl. HD couplings
- with bending protector

Artikel-Nr. Order-No.	Ident-Nr. Ident-No.	L	
HDH2	77485	2000	1100
HDH3	77486	3000	1600
HDH4	77487	4000	2100

andere Längen auf Anfrage

other lengths on request

HDH



BOLTMAX

xt

Montage- und Demontagesystem für Plattenwärmetauscher

Die Vorteile:

- effizientes Arbeiten (nur ein Bediener erforderlich)
- hohe Arbeitsgeschwindigkeit (ca. 10 Min zur Demontage eines Kühlers mit M39 Spindeln)
- hohe Präzision durch genaue Kraftkontrolle (Manometer/Druckbegrenzungsventil)
- große Flexibilität durch wechselbare Komponenten
- sicheres Arbeiten in explosionsgefährdeten Bereichen (mit Lufthydraulikpumpe)
- sicheres Arbeiten (kein ausdrücken der Gewindestangen)
- keine Drucklager erforderlich
- kompakte Bauweise
- wartungsarm (keine hochbelasteten Zahnräder)

Assembly and torque tool for plate- Heat exchanger

Advantages:

- efficient working (only 1 operator necessary)
- high working speed (about 10 min. for dismantling of a cooler with M39 spindle)
- high precision by exact power control (manometer/power limiting valve)
- high flexibility by changeable components
- safe working in explosion hazardous areas (with air hydraulic pump)
- safe working (no extracting of spindle bolts)
- no thrust bearing required
- compact construction
- with only little wear and tear (no highly loaded gears)



BOLTMAX

xt

Die Einsatzgebiete

- Schiff- und Motorenbau
- Lebensmittelindustrie
- Zuckerindustrie
- Extraktionsanlagen
- chemische Industrie
- Off shore
- Stahlindustrie
- Kraftwerke
- Maschinenbau
- Kolben- und Turbomaschinen
- Pharmaindustrie
- Papierindustrie
- Textilindustrie

Fields of application:

- ship industry
- food industry
- sugar industry
- extracting plants
- chemical industry
- off-shore
- steel industry
- power generating plants
- machine industry
- piston and turbo machines
- pharmaceutical industry
- paper industry
- textile industry

BOLTMAX

300 kN

xt

BMXTBS
Basis-System 77429
bestehend aus je 2 Stück

BMXTBS
basic system 77429
consisting of 2 pcs. each

Artikel-Nr. Order-No.	Ident-Nr. Ident-No.		F
BMXTBS	77429		300KN

BMXTBS



79655
BMXT300
Zylinder

79655
BMXT300
cylinder



242445593000
BMXTGI
Gehäuse

242445593000
BMXTGI
housing



77987
HD5
5m Schlauch

77987
HD5
5m hose



242440710000
BMXTS
Spuleinrichtung

242440710000
BMXTS
nut support



24244
2070-14
Ratsche

24244
2070-14
ratchet

BOLTMAX M22 - M48

xt

BMXTB
Buchse

BMXTB
bushing

BMXTB

Artikel-Nr. Order-No.	Ident-Nr. Ident-No.		
BMXTB22	242445592122		M 22
BMXTB24	242445592124		M 24
BMXTB27	242445592127		M 27
BMXTB30	242445592130		M 30
BMXTB33	242445592133		M 33
BMXTB36	242445592136		M 36
BMXTB39	242445592139		M 39
BMXTB42	242445592142		M 42
BMXTB45	242445592145		M 45
BMXTB48	242445592148		M 48



BOLTMAX M22 - M48

xt

BMXTM
Geteilte Mutter

BMXTM
Split nut

BMXTM

Artikel-Nr. Order-No.	Ident-Nr. Ident-No.		
BMXTM22	242445593122		M 22
BMXTM24	242445593124		M 24
BMXTM27	242445593127		M 27
BMXTM30	242445593130		M 30
BMXTM33	242445593133		M 33
BMXTM36	242445593136		M 36
BMXTM39	242445593139		M 39
BMXTM42	242445593142		M 42
BMXTM45	242445593145		M 45
BMXTM48	242445593148		M 48



BOLTMAX SW 32 - 80

xt

BMXTSW
Sw-Adapter

BMXTSW
hex adapter

BMXTSW

Artikel-Nr. Order-No.	Ident-Nr. Ident-No.		[mm]
BMXTSW32	242445595632		32
BMXTSW36	242445595636		36
BMXTSW41	242445595641		41
BMXTSW46	242445595646		46
BMXTSW50	242445595650		50
BMXTSW55	242445595655		55
BMXTSW60	242445595660		60
BMXTSW65	242445595665		65
BMXTSW70	242445595670		70
BMXTSW75	242445595675		75
BMXTSW80	242445595680		80



BOLTMAX

136-2.615 kN / 1000 bar

tension

Hydraulische-Schrauben-Vorspanner

- hohe Genauigkeit
- einfache Anwendung
- sicherer Einsatz
- Hohe Wirtschaftlichkeit und Flexibilität durch die Anwendung gemeinsamer Hydraulik-Zylinder mit:
 - wechselbaren Zugmuttern
 - wechselbaren Schlüsselweiten
 - wechselbaren Stützhülsen
- Der Gewindeüberstand muß mindestens dem Bolzendurchmesser entsprechen (Mutterhöhe = Bolzendurchmesser)



Hub stroke	
6 mm	02BMT
8 mm	01BMT
15 mm	1BMT-10BMT

Komplettgeräte

complete tensioners

Artikel-Nr. Order-No.	Ident-Nr. Ident-No.		Fp [kN]	AØ [mm]	B [mm]	D [mm]	
02BMT16	75000	M16	136	73,5	23,5	160	1450
02BMT18	75002	M18	136	73,5	23,5	160	1450
02BMT20	75004	M20	136	73,5	26,5	160	1480
02BMT22	75006	M22	136	73,5	26,5	160	1480
01BMT24	75008	M24	228	86,0	29,5	180	2310
01BMT27	75010	M27	228	86,0	32,0	185	2340
1BMT30	75012	M30	348	107,0	36,0	197	3460
1BMT33	75014	M33	348	107,0	36,0	197	3460
2BMT33	75016	M33	428	117,0	36,0	199	3930
2BMT36	75018	M36	428	117,0	39,0	202	3890
1BMT36	75020	M36	348	107,0	39,0	200	3420
2BMT39	75022	M39	428	117,0	42,0	213	4400
3BMT39	75024	M39	591	136,0	42,0	212	5360
3BMT42	75026	M42	591	136,0	45,0	214	5700
4BMT42	75028	M42	788	150,0	45,0	216	6900
3BMT45	75030	M45	591	136,0	49,0	217	5800
4BMT45	75032	M45	788	150,0	49,0	219	7000
4BMT48	75034	M48	788	150,0	51,0	222	7200
5BMT52	75036	M48	989	169,0	51,0	222	8050
4BMT52	75038	M52	788	150,0	54,0	225	7500
5BMT52	75040	M52	989	169,0	54,0	225	8350
5BMT56	75042	M56	989	169,0	59,0	231	9120
6BMT56	75044	M56	1274	190,0	59,0	241	10670
6BMT60	75046	M60	1274	190,0	65,0	248	11270
6BMT64	75048	M64	1274	190,0	65,0	248	11270
7BMT64	75050	M64	1594	208,0	65,0	252	12670
7BMT68	75052	M68	1594	208,0	71,0	258	14150
7BMT72	75054	M72	1594	208,0	71,0	258	14150
8BMT72	75056	M72	1832	222,0	71,0	258	15550
8BMT76	75058	M76	1832	222,0	77,0	265	17800
9BMT76	75060	M76	2178	239,0	77,0	267	20800
9BMT80	75062	M80	2178	239,0	77,0	274	20800
9BMT85	75064	M85	2178	239,0	87,0	274	22600
9BMT90	75066	M90	2178	239,0	93,0	281	22100
10BMT95	75068	M95	2615	276,0	99,0	296	50000
10BMT100	75070	M100	2615	276,0	100,0	302	54000

hydraulic bolt tensioners

- high accuracy
- simple usage
- safe working
- high versatility by using common hydraulic cylinders with:
 - interchangeable pullers
 - interchangeable nuts
 - interchangeable bridges
- Thread engagement required is minimum one x bolt diameter (nut height = bolt diameter)

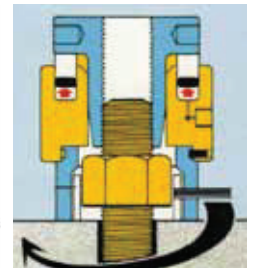
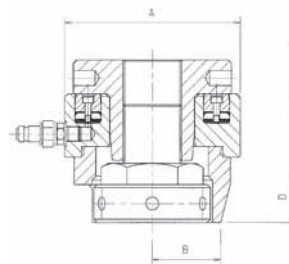

Adaptersätze *

adapter sets *

Artikel-Nr. Order-No.	Ident-Nr. Ident-No.		für for
02BMT16A	75001	M16	02
02BMT18A	75003	M18	02
02BMT20A	75005	M20	02
02BMT22A	75007	M22	02
01BMT24A	75009	M24	01
01BMT27A	75011	M27	01
1BMT30A	75013	M30	1
1BMT33A	75015	M33	1
2BMT33A	75017	M33	2
2BMT36A	75019	M36	2
1BMT36A	75021	M36	1
2BMT39A	75023	M39	2
3BMT39A	75025	M39	3
3BMT42A	75027	M42	3
4BMT42A	75029	M42	4
3BMT45A	75031	M45	3
4BMT45A	75033	M45	4
4BMT48A	75035	M48	4
5BMT52A	75037	M48	5
4BMT52A	75039	M52	4
5BMT52A	75041	M52	5
5BMT56A	75043	M56	5
6BMT56A	75045	M56	6
6BMT60A	75047	M60	6
6BMT64A	75049	M64	6
7BMT64A	75051	M64	7
7BMT68A	75053	M68	7
7BMT72A	75055	M72	7
8BMT72A	75057	M72	8
8BMT76A	75059	M76	8
9BMT76A	75061	M76	9
9BMT80A	75063	M80	9
9BMT85A	75065	M85	9
9BMT90A	75067	M90	9
10BMT95A	75069	M95	10
10BMT100A	75071	M100	10

* SW-Adapter; Stützhülse, Zugmuttern * nuts, bridge, puller

BOLTMAX 217-2080 kN / 1400 bar



tension HN

Hydraulikmuttern

- schnell, genau und zuverlässig
- problemloses Nachspannen
- einfache Anwendung
- Vorspannkraft wird durch Überwurfmutter gesichert
- seitliche Kupplungen sind möglich

Hydraulic nuts

- quick, accurate and reliable
- easy re-adjustment of tension
- simply use
- load is retained by threaded collar
- side entry is available (option)

Artikel-Nr. Order-No.	Ident-Nr. Ident-No.			Fp [kN]	AØ[mm]	C [mm]	Hub max. [mm]	
BMHN1/16	77400		M16	217	74	66	4	2080
BMHN1/18	77401		M18	217	74	66	4	2080
BMHN1/20	77402		M20	217	74	66	4	2080
BMHN1/22	77403		M22	217	74	66	4	2080
BMHN1/24	77404		M24	217	74	66	4	2080
BMHN1/27	77405		M27	217	74	66	4	2080
BMHN1/30	77406		M30	217	74	66	4	2080
BMHN2/30	77407		M30	350	95	66	4	3250
BMHN2/33	77408		M33	350	95	66	4	3250
BMHN2/36	77409		M36	350	95	66	4	3250
BMHN2/39	77410		M39	350	95	66	4	3250
BMHN3/42	77411		M42	440	108	74	4	4420
BMHN3/45	77412		M45	440	108	74	4	4420
BMHN3/48	77413		M48	440	108	74	4	4420
BMHN3/52	77414		M52	440	108	74	4	4420
BMHN4/56	77415		M56	552	118	78	4	5130
BMHN5/60	77416		M60	617	128	84	5	6390
BMHN5/64	77417		M64	617	128	84	5	6390
BMHN6/68	77418		M68	777	140	88	6	7980
BMHN7/72	77419		M72	1039	162	92	6	11580
BMHN7/76	77420		M76	1039	162	92	6	11580
BMHN7/80	77421		M80	1039	162	92	6	11580
BMHN8/80	77422		M80	1462	185	112	8	18910
BMHN8/90	77423		M90	1462	185	112	8	18910
BMHN9/90	77424		M90	1625	202	122	8	23850
BMHN9/100	77425		M100	1625	202	122	8	23850
BMHN10/100	77426		M100	2080	218	137	10	31400

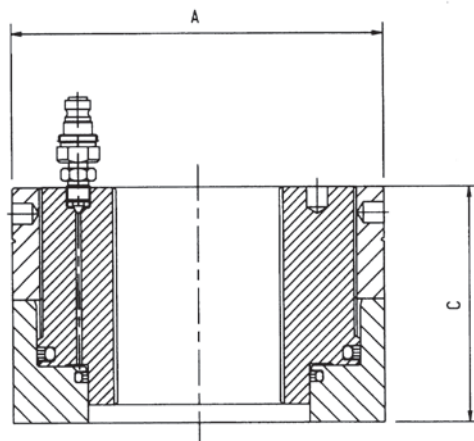
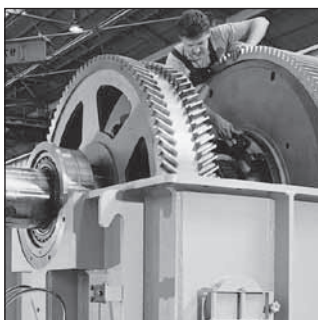
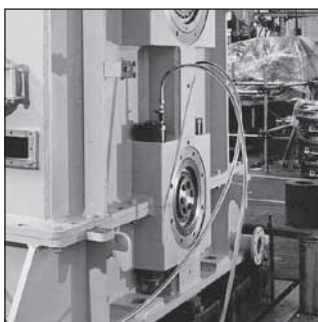

BMHN

