

# Schraubenschlüssel

**Spanners & wrenches**

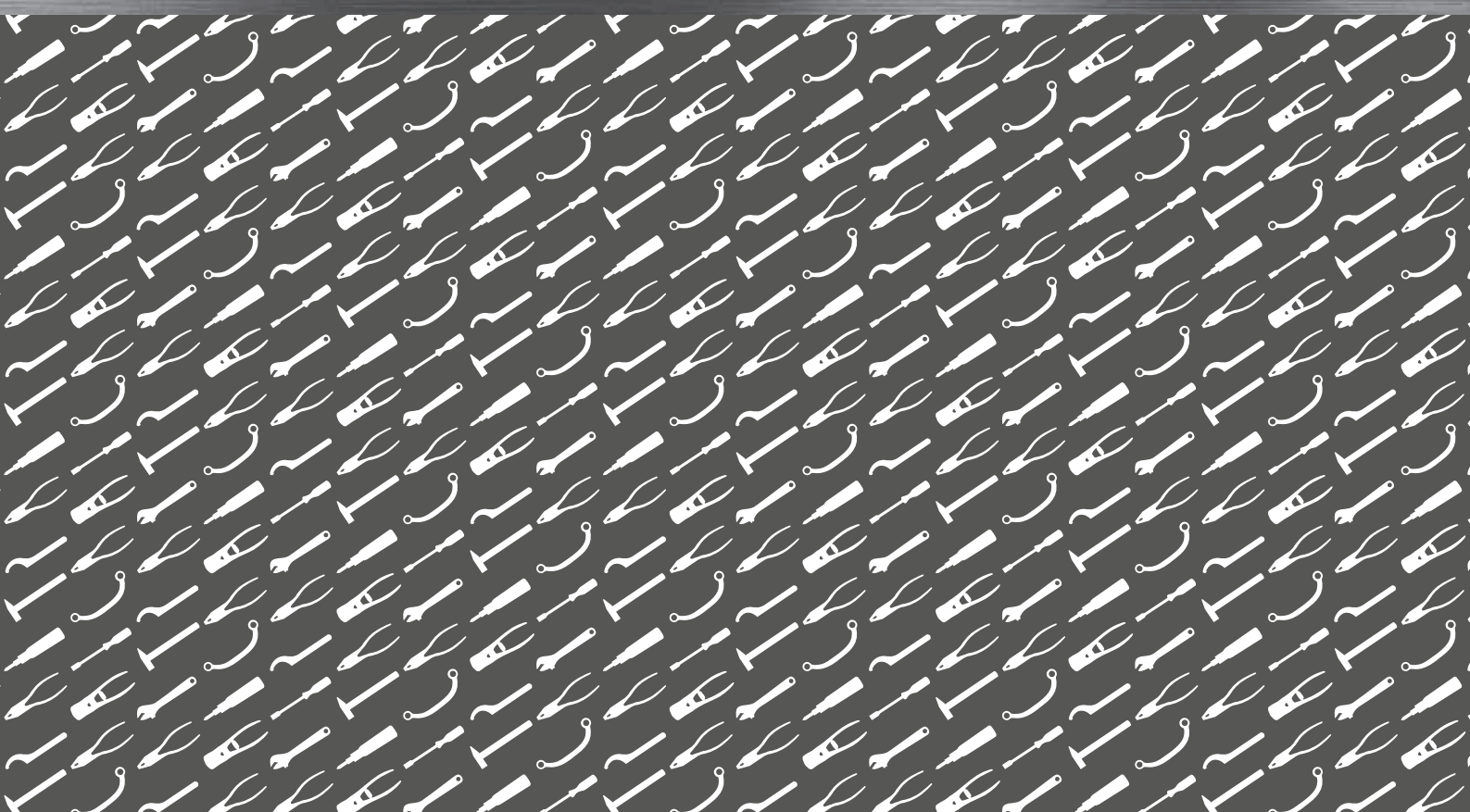

# Schraubenschlüssel Spanners & wrenches

Vom Elektrikerschlüssel Nr. 160 - 3,2 mm bis zum Schlag-schlüssel Nr. 580 - 230 mm stellen die Schraubenschlüssel die Basis des Carl Walter Programms dar. Aus gutem Grund vertrauen Ingenieure und Mechaniker seit mehr als 80 Jahren auf die bewährte Qualität von Walter Schlüsseln:

- Walter Schlüsseln übertreffen die Anforderungen von nationalen und internationalen Normen.
- Aufgrund sorgfältiger Konstruktion und Berechnung werden hohe Drehmomente bei geringen Abmessungen erreicht.
- Walter ENERGY Profil als Standard. Dieses Profil verlagert beim Schrauben den Belastungspunkt von der Ecke zur Flanke des Schraubenkopfes. Dadurch wird der Schraubenkopf geschont und die Drehmomente können noch weiter erhöht werden.
- Walter Schlüsseln werden aus hochwertigem Vergütungsstahl (31CrV3 / 51CrV4, etc.) im Gesenk geschmiedet.
- Die Schlüsselweiten werden durch spanende Bearbeitung kalibriert.
- Um einer Randentkohlung (Weichhaut) bei der Wärmebehandlung entgegenzuwirken, erfolgt die Vergütung der Walter Schlüsseln unter Ausschluss von Sauerstoff.
- Bei Walter Schlüsseln können Sie zwischen zwei verschiedenen Oberflächen-Ausführungen wählen:
  - einer hochwertigen, dauerhaften Matt-Verchromung
  - einer schlagbeständigen Phosphatierung, die einen dauerhaften Korrosionsschutz bietet.
- Zur Sicherung des hohen Qualitätsniveaus unterliegen die Schraubenschlüssel wie alle Produkte des Hauses Carl Walter ständigen Qualitätskontrollen.

From electrician spanner Nr. 160 size 3,2 mm up to a slugging wrench Nr. 580 size 230 mm the production of spanners and wrenches is the basis of the CARL WALTER range. There are good reasons why engineers and mechanics rely on Walter spanners for more than 80 years:

- Walter spanners comply with or exceed the requirements of the relevant national and international standards.
- Due to our know-how in spanner production Walter spanners and wrenches designed to offer highest loadability at smallest possible dimensions.
- All popular metric ring spanners with the Walter Energy-profile as standard. This transfers the loading point from the corner of the bolt to the flanks which protects the bolt from any damage and allows to even further increase applicable loads.
- Walter spanners are drop forged from high quality alloyed steels (31CrV3 / 51CrV4, etc.).
- Walter spanners are calibrated by cutting processes.
- To prevent from a decarbonization of surface, all Walter spanners are heat treated under exclusion of oxygen.
- On Walter spanners you can select out of two different finishes:
  - a high quality, durable chrome plating in matt finish
  - an impact-resistant phosphating for a permanent protection against corrosion.
- To guarantee the high quality level the Walter spanners as well as all other products of our company are constantly surveyed by our quality control department.



Profilprojektor, Energy-Profil  
profile projector, Energy- profile

# Schraubenschlüssel Spanners & wrenches

Doppelmaulschlüssel

DIN 3110 – ISO 3318 / ISO 1085

Chrom-Vanadium-Stahl, verchromt, Köpfe geschliffen,

Maulstellung: 15°

Double open ended spanner

DIN 3110 – ISO 3318 / ISO 1085

chrome vanadium steel, chrome plated,

heads smoothly grinded, position of open ends: 15°

100 C



| Artikel-Nr.<br>Order-No. | Ident-Nr.<br>Ident-No. | $\updownarrow$ mm |  | L   |      |    |
|--------------------------|------------------------|-------------------|--|-----|------|----|
| 100 C                    | 00052                  | 4 x 5             |  | 110 | 16   | 10 |
| 100 C                    | 00092                  | 6 x 7             |  | 123 | 22   | 10 |
| 100 C                    | 00102                  | 7 x 8             |  | 132 | 30   | 10 |
| 100 C                    | 00122                  | 8 x 9             |  | 143 | 30   | 10 |
| 100 C                    | 00132                  | 8 x 10            |  | 143 | 30   | 10 |
| 100 C                    | 00152                  | 9 x 11            |  | 157 | 46   | 10 |
| 100 C                    | 00162                  | 10 x 11           |  | 157 | 48   | 10 |
| 100 C                    | 00172                  | 10 x 12           |  | 157 | 45   | 10 |
| 100 C                    | 00182                  | 10 x 13           |  | 171 | 64   | 10 |
| 100 C                    | 00192                  | 11 x 13           |  | 171 | 69   | 10 |
| 100 C                    | 00202                  | 12 x 13           |  | 172 | 64   | 10 |
| 100 C                    | 00222                  | 12 x 14           |  | 180 | 69   | 10 |
| 100 C                    | 00232                  | 13 x 14           |  | 180 | 81   | 10 |
| 100 C                    | 00242                  | 13 x 15           |  | 190 | 88   | 10 |
| 100 C                    | 00252                  | 14 x 15           |  | 190 | 88   | 10 |
| 100 C                    | 00032                  | 13 x 16           |  | 190 | 100  | 10 |
| 100 C                    | 00262                  | 13 x 17           |  | 190 | 96   | 10 |
| 100 C                    | 00272                  | 14 x 17           |  | 190 | 97   | 10 |
| 100 C                    | 00282                  | 16 x 17           |  | 205 | 124  | 10 |
| 100 C                    | 00532                  | 16 x 18           |  | 220 | 110  | 10 |
| 100 C                    | 00292                  | 17 x 19           |  | 220 | 156  | 10 |
| 100 C                    | 00302                  | 18 x 19           |  | 220 | 156  | 10 |
| 100 C                    | 00072                  | 18 x 21           |  | 235 | 214  | 10 |
| 100 C                    | 00322                  | 19 x 22           |  | 235 | 209  | 10 |
| 100 C                    | 00332                  | 20 x 22           |  | 237 | 200  | 10 |
| 100 C                    | 00342                  | 21 x 23           |  | 250 | 235  | 5  |
| 100 C                    | 00352                  | 19 x 24           |  | 245 | 240  | 5  |
| 100 C                    | 00512                  | 21 x 24           |  | 250 | 230  | 5  |
| 100 C                    | 00362                  | 22 x 24           |  | 250 | 244  | 5  |
| 100 C                    | 00382                  | 24 x 26           |  | 270 | 320  | 5  |
| 100 C                    | 00392                  | 24 x 27           |  | 270 | 295  | 5  |
| 100 C                    | 00402                  | 24 x 30           |  | 285 | 360  | 5  |
| 100 C                    | 00412                  | 25 x 28           |  | 280 | 370  | 5  |
| 100 C                    | 00432                  | 27 x 30           |  | 295 | 466  | 5  |
| 100 C                    | 00442                  | 27 x 32           |  | 302 | 468  | 5  |
| 100 C                    | 00452                  | 30 x 32           |  | 295 | 492  | 5  |
| 100 C                    | 00612                  | 30 x 34           |  | 320 | 477  | 3  |
| 100 C                    | 00462                  | 30 x 36           |  | 320 | 526  | 3  |
| 100 C                    | 00642                  | 32 x 34           |  | 323 | 600  | 3  |
| 100 C                    | 00472                  | 32 x 36           |  | 323 | 600  | 3  |
| 100 C                    | 00622                  | 34 x 36           |  | 323 | 586  | 3  |
| 100 C                    | 00482                  | 36 x 41           |  | 350 | 723  | 3  |
| 100 C                    | 00492                  | 41 x 46           |  | 425 | 1295 | 1  |
| 100 C                    | 00502                  | 46 x 50           |  | 475 | 1665 | 1  |
| 100 C                    | 00632                  | 55 x 60           |  | 627 | 3135 | 1  |

Amerikanische Zollmaße AF"

AF"

| Artikel-Nr.<br>Order-No. | Ident-Nr.<br>Ident-No. | $\updownarrow$ AF"  |  | L   |     |    |
|--------------------------|------------------------|---------------------|--|-----|-----|----|
| 100 C                    | 00652                  | $1/4 \times 5/16$   |  | 123 | 20  | 10 |
| 100 C                    | 00662                  | $5/16 \times 3/8$   |  | 143 | 34  | 10 |
| 100 C                    | 00672                  | $3/8 \times 7/16$   |  | 157 | 46  | 10 |
| 100 C                    | 00682                  | $7/16 \times 1/2$   |  | 171 | 74  | 10 |
| 100 C                    | 00692                  | $1/2 \times 9/16$   |  | 180 | 83  | 10 |
| 100 C                    | 00702                  | $9/16 \times 5/8$   |  | 190 | 89  | 10 |
| 100 C                    | 00712                  | $5/8 \times 11/16$  |  | 205 | 135 | 10 |
| 100 C                    | 00722                  | $5/8 \times 3/4$    |  | 220 | 165 | 10 |
| 100 C                    | 00732                  | $11/16 \times 3/4$  |  | 220 | 169 | 10 |
| 100 C                    | 00742                  | $3/4 \times 7/8$    |  | 235 | 230 | 10 |
| 100 C                    | 00752                  | $13/16 \times 7/8$  |  | 236 | 207 | 10 |
| 100 C                    | 00772                  | $15/16 \times 1$    |  | 270 | 308 | 5  |
| 100 C                    | 00792                  | $1 \times 11/8$     |  | 280 | 356 | 5  |
| 100 C                    | 00802                  | $11/16 \times 11/4$ |  | 302 | 430 | 5  |
| 100 C                    | 00822                  | $17/16 \times 15/8$ |  | 355 | 736 | 1  |



# Schraubenschlüssel Spanners & wrenches

Satz in Karton

Set in carton

| Artikel-Nr.<br>Order-No. | Ident-Nr.<br>Ident-No. | Inhalt<br>Content   | mm |      |   |
|--------------------------|------------------------|---|----|------|---|
| 100/6 C                  | 00542                  | 6x7, 8x9, 10x11, 12x13, 14x15, 16x17  |    | 380  | I |
| 100/7 C                  | 00552                  | 6x7, 8x9, 10x11, 12x13, 14x15, 16x17, 18x19                                   |    | 660  | I |
| 100/8 C                  | 00572                  | 6x7, 8x9, 10x11, 12x13, 14x15, 16x17, 18x19, 20x22                            |    | 860  | I |
| 100/10 C                 | 00582                  | 6x7, 8x9, 10x11, 12x13, 14x15, 16x17, 18x19, 20x22, 21x23, 24x27              |    | 1390 | I |
| 100/12 C                 | 00592                  | 6x7, 8x9, 10x11, 12x13, 14x15, 16x17, 18x19, 20x22, 21x23, 24x27, 25x28, 0x32 |    | 2250 | I |



100 C

Amerikanische Zollmaße AF"

AF"

| Artikel-Nr.<br>Order-No. | Ident-Nr.<br>Ident-No. | Inhalt<br>Content  | AF" |      |   |
|--------------------------|------------------------|--|-----|------|---|
| 100/6 C                  | 00892                  | 1/4 x 5/16, 3/8 x 7/16, 1/2 x 9/16, 5/8 x 3/4, 13/16 x 7/8, 15/16 x 1  |     | 830  | I |
| 100/8 C                  | 00902                  | 1/4 x 5/16, 5/16 x 3/8, 7/16 x 1/2, 9/16 x 5/8, 11/16 x 3/4, 13/16 x 7/8, 15/16 x 1, 1 1/16 x 1 1/4  |     | 1340 | I |
| 100/12 C                 | 01042                  | 1/4 x 5/16, 5/16 x 3/8, 3/8 x 7/16, 7/16 x 1/2, 1/2 x 9/16, 9/16 x 5/8, 11/16 x 3/4, 13/16 x 7/8, 15/16 x 1, 1 x 1 1/8, 1 1/16 x 1 1/4, 1 7/16 x 1 5/8 |     | 2560 | I |

Satz in Sichtkarton

Set in display carton

| Artikel-Nr.<br>Order-No. | Ident-Nr.<br>Ident-No. | Inhalt<br>Content                                  | mm |     |   |
|--------------------------|------------------------|--|----|-----|---|
| 100/8 C                  | 100 0083 020           | 6x7, 8x9, 10x11, 12x13, 14x15, 16x17, 18x19, 20x22 |    | 650 | I |



100 C



Härten  
harden

# Schraubenschlüssel Spanners & wrenches

**Elektronik-Doppelmaulschlüssel**  
beide Seiten gleiche Schlüsselweite,  
15° und 75° abgewinkelt, extra dünne Mäuler,  
Spezial-Werkzeugstahl, verchromt

**Electronic' double open ended spanner**  
samesize at both ends,  
jaws angled 15° and 75°,extra thin jaws,  
special tool steel, chrome plated



160

| Artikel-Nr.<br>Order-No. | Ident-Nr.<br>Ident-No. | mm  | L   |    |    |
|--------------------------|------------------------|-----|-----|----|----|
| 160                      | 160 0032 010           | 3,2 | 65  | 5  | 10 |
| 160                      | 160 0035 010           | 3,5 | 65  | 5  | 10 |
| 160                      | 160 0004 010           | 4   | 65  | 5  | 10 |
| 160                      | 160 0045 010           | 4,5 | 65  | 5  | 10 |
| 160                      | 160 0005 010           | 5   | 65  | 6  | 10 |
| 160                      | 160 0055 010           | 5,5 | 75  | 6  | 10 |
| 160                      | 160 0006 010           | 6   | 75  | 6  | 10 |
| 160                      | 160 0007 010           | 7   | 90  | 8  | 10 |
| 160                      | 160 0008 010           | 8   | 90  | 15 | 10 |
| 160                      | 160 0009 010           | 9   | 100 | 17 | 10 |
| 160                      | 160 0010 010           | 10  | 100 | 20 | 10 |
| 160                      | 160 0011 010           | 11  | 115 | 28 | 10 |
| 160                      | 160 0012 010           | 12  | 115 | 28 | 10 |
| 160                      | 160 0013 010           | 13  | 130 | 35 | 10 |
| 160                      | 160 0014 010           | 14  | 130 | 35 | 10 |

Amerikanische Zollmaße AF"

AF"

| Artikel-Nr.<br>Order-No. | Ident-Nr.<br>Ident-No. | AF"   | L   |    |    |
|--------------------------|------------------------|-------|-----|----|----|
| 160                      | 160 8106 010           | 5/32  | 65  | 5  | 10 |
| 160                      | 160 8107 010           | 3/16  | 65  | 5  | 10 |
| 160                      | 160 8111 010           | 1/4   | 75  | 6  | 10 |
| 160                      | 160 8115 010           | 5/16  | 90  | 8  | 10 |
| 160                      | 160 8117 010           | 11/32 | 100 | 18 | 10 |
| 160                      | 160 8118 010           | 3/8   | 100 | 18 | 10 |
| 160                      | 160 8120 010           | 7/16  | 115 | 28 | 10 |
| 160                      | 160 8122 010           | 1/2   | 130 | 35 | 10 |
| 160                      | 160 8124 010           | 9/16  | 130 | 35 | 10 |

Satz in Kunstleder-Tasche

Set in plastic bag

| Artikel-Nr.<br>Order-No. | Ident-Nr.<br>Ident-No. | Inhalt<br>Content  | mm  |   |  |
|--------------------------|------------------------|--|-----|---|--|
| 160/10                   | 160 0106 010           | 3,2, 3,5, 4, 4,5, 5, 5,5, 6, 7, 8, 9                     | 180 | 1 |  |
| 160/15                   | 160 0156 010           | 3,2, 3,5, 4, 4,5, 5, 5,5, 6, 7, 8, 9, 10, 11, 12, 13, 14 | 360 | 1 |  |



160

Amerikanische Zollmaße AF"

AF"

| Artikel-Nr.<br>Order-No. | Ident-Nr.<br>Ident-No. | Inhalt<br>Content                                  | AF" |   |  |
|--------------------------|------------------------|--|-----|---|--|
| 160/9                    | 160 0096 010           | 5/32, 3/16, 1/4, 5/16, 11/32, 3/8, 7/16, 1/2, 9/16 | 170 | 1 |  |

**Verstellbare Einmaulschlüssel**  
DIN 3117 Form B – ISO 6787  
Form Crescent, Chrom-Vanadium-Stahl, verchromt,  
Kopf hochglanzpoliert

**Adjustable single ended spanner**  
DIN 3117 Form B – ISO 6787  
form CRESCENT, chrome vanadium steel, chrome  
plated, head mirror polished



210

| Artikel-Nr.<br>Order-No. | Ident-Nr.<br>Ident-No. | Größe<br>Size | mm<br>max. | L   |      |   |
|--------------------------|------------------------|---------------|------------|-----|------|---|
| 210                      | 03858                  | 4"            | 14         | 110 | 50   | 5 |
| 210                      | 03868                  | 6"            | 20         | 160 | 105  | 5 |
| 210                      | 03878                  | 8"            | 25         | 210 | 220  | 5 |
| 210                      | 03888                  | 10"           | 29         | 260 | 390  | 5 |
| 210                      | 03898                  | 12"           | 34         | 310 | 650  | 5 |
| 210                      | 03908                  | 15"           | 44         | 380 | 1170 | 1 |
| 210                      | 03918                  | 18"           | 53         | 460 | 2100 | 1 |

# Schraubenschlüssel Spanners & wrenches

Ring-Maulschlüssel **ENERGY** 

DIN 3113 Form A – ISO 3318

kurze Ausführung, Ringsseite 15° abgewinkelt,

Chrom-Vanadium-Stahl, verchromt, Köpfe geschliffen,

alle mm-Größen mit **ENERGY**-Profil auf der Ringsseite

Combination spanner **ENERGY** 

DIN 3113 Form A – ISO 3318



short pattern, ring end 15° angled, chrome vanadium

steel, chrome plated, heads smoothly grinded,

all mm-sizes with **ENERGY**-profile at ring end

280 C





| Artikel-Nr.<br>Order-No. | Ident-Nr.<br>Ident-No. | $\overline{\Delta}$ mm |  | L   |  |  |
|--------------------------|------------------------|------------------------|--|-----|---|---|
| 280 C                    | 05012                  | 6                      |  | 100 | 14  | 10  |
| 280 C                    | 05022                  | 7                      |  | 110 | 19  | 10  |
| 280 C                    | 05032                  | 8                      |  | 120 | 26  | 10  |
| 280 C                    | 05042                  | 9                      |  | 130 | 32  | 10  |
| 280 C                    | 05052                  | 10                     |  | 140 | 39  | 10  |
| 280 C                    | 05062                  | 11                     |  | 150 | 49  | 10  |
| 280 C                    | 05072                  | 12                     |  | 160 | 58  | 10  |
| 280 C                    | 05082                  | 13                     |  | 170 | 89  | 10  |
| 280 C                    | 05092                  | 14                     |  | 180 | 84  | 10  |
| 280 C                    | 05102                  | 15                     |  | 190 | 97  | 10  |
| 280 C                    | 05112                  | 16                     |  | 200 | 105   | 10  |
| 280 C                    | 05122                  | 17                     |  | 210 | 130   | 10  |
| 280 C                    | 05132                  | 18                     |  | 210 | 125   | 10  |
| 280 C                    | 05142                  | 19                     |  | 230 | 180   | 10  |
| 280 C                    | 05152                  | 20                     |  | 230 | 188   | 10  |
| 280 C                    | 05162                  | 21                     |  | 240 | 203   | 10  |
| 280 C                    | 05172                  | 22                     |  | 260 | 249   | 10  |
| 280 C                    | 05182                  | 23                     |  | 260 | 215   | 5   |
| 280 C                    | 05192                  | 24                     |  | 280 | 280   | 5   |
| 280 C                    | 05202                  | 25                     |  | 280 | 260   | 5   |
| 280 C                    | 05212                  | 26                     |  | 300 | 302   | 5   |
| 280 C                    | 05222                  | 27                     |  | 300 | 380   | 5   |
| 280 C                    | 05232                  | 28                     |  | 300 | 357   | 5   |
| 280 C                    | 05242                  | 30                     |  | 332 | 472   | 5   |
| 280 C                    | 05252                  | 32                     |  | 360 | 555   | 5   |
| 280 C                    | 04992                  | 34                     |  | 380 | 690   | 3   |
| 280 C                    | 05262                  | 36                     |  | 380 | 670   | 3   |

Amerikanische Zollmaße AF<sup>°</sup>

ohne **ENERGY**-profil

AF<sup>°</sup>

without **ENERGY**-profil

| Artikel-Nr.<br>Order-No. | Ident-Nr.<br>Ident-No. | $\overline{\Delta}$ AF <sup>°</sup> |  | L   |  |  |
|--------------------------|------------------------|-------------------------------------|--|-----|---|---|
| 280 C                    | 05352                  | 1/4                                 |  | 100 | 20  | 10  |
| 280 C                    | 05362                  | 5/16                                |  | 120 | 27  | 10  |
| 280 C                    | 05372                  | 3/8                                 |  | 130 | 32  | 10  |
| 280 C                    | 05382                  | 7/16                                |  | 150 | 49  | 10  |
| 280 C                    | 05392                  | 1/2                                 |  | 170 | 89  | 10  |
| 280 C                    | 05402                  | 9/16                                |  | 180 | 82  | 10  |
| 280 C                    | 05412                  | 5/8                                 |  | 200 | 122   | 10  |
| 280 C                    | 05422                  | 11/16                               |  | 210 | 125   | 10  |
| 280 C                    | 05432                  | 3/4                                 |  | 230 | 174   | 10  |
| 280 C                    | 05442                  | 13/16                               |  | 240 | 203   | 10  |
| 280 C                    | 05452                  | 7/8                                 |  | 260 | 226   | 10  |
| 280 C                    | 05462                  | 15/16                               |  | 280 | 303   | 5   |
| 280 C                    | 05472                  | 1                                   |  | 280 | 280   | 5   |
| 280 C                    | 05482                  | 1 1/16                              |  | 300 | 358   | 5   |
| 280 C                    | 05492                  | 1 1/8                               |  | 300 | 489   | 5   |
| 280 C                    | 05502                  | 1 1/4                               |  | 360 | 491   | 5   |



Satz in Karton

**ENERGY**

Set in carton

**ENERGY**

280 C

| Artikel-Nr.<br>Order-No. | Ident-Nr.<br>Ident-No. | Inhalt<br>Content  | $\overline{\Delta}$ mm |  |  |
|--------------------------|------------------------|--|------------------------|---|---|
| 280/8 C                  | 05002                  | 8, 10, 11, 13, 14, 17, 19, 22                                |                        | 850   | I   |
| 280/12 C                 | 05322                  | 8, 9, 10, 11, 12, 13, 14, 15, 17, 19, 21, 22                 |                        | 1485  | I   |
| 280/120 C                | 05332                  | 6, 7, 8, 9, 10, 11, 12, 13, 14, 17, 19, 22                   |                        | 950   | I   |
| 280/16 C                 | 05342                  | 8, 9, 10, 11, 12, 13, 14, 15, 17, 19, 21, 22, 24, 27, 30, 32 |                        | 3175  | I   |





Amerikanische Zollmaße AF<sup>°</sup>

ohne **ENERGY**-profil

AF<sup>°</sup>

without **ENERGY**-profil

| Artikel-Nr.<br>Order-No. | Ident-Nr.<br>Ident-No. | Inhalt<br>Content  | $\overline{\Delta}$ AF <sup>°</sup> |  |  |
|--------------------------|------------------------|--|-------------------------------------|---|---|
| 280/9 C                  | 05552                  | 1/4, 5/16, 3/8, 7/16, 1/2, 9/16, 5/8, 11/16, 3/4   |                                     | 720   | I   |
| 280/16 C                 | 05572                  | 1/4, 5/16, 3/8, 7/16, 1/2, 9/16, 5/8, 11/16, 3/4, 13/16, 7/8, 15/16, 1, 1 1/16, 1 1/8, 1 1/4 |                                     | 3070  | I   |

# Schraubenschlüssel Spanners & wrenches

## Ratschfix **ENERGY**

ratschender Maul-Ringschlüssel,  
Ring mit **ENERGY**-Profil 15° abgewinkelt,  
Länge nach DIN 3113 A Chrom-Vanadium-Stahl,  
verchromt, Köpfe geschliffen, Super-Finish

## Combination spanner **ENERGY**

with ratcheting open end,  
ring with **ENERGY**-profile, 15° angled, length as per DIN  
3113 A, chrome vanadium steel, chrome plated, heads  
smoothly grinded, Super-Finish



280 R

| Artikel-Nr.<br>Order-No. | Ident-Nr.<br>Ident-No. | mm | L   | ⚖️  | 📏  |
|--------------------------|------------------------|----|-----|-----|----|
| 280 R                    | 275 0080 020           | 8  | 120 | 26  | 10 |
| 280 R                    | 275 0090 020           | 9  | 130 | 32  | 10 |
| 280 R                    | 275 0100 020           | 10 | 140 | 39  | 10 |
| 280 R                    | 275 0110 020           | 11 | 150 | 49  | 10 |
| 280 R                    | 275 0120 020           | 12 | 160 | 59  | 10 |
| 280 R                    | 275 0130 020           | 13 | 170 | 69  | 10 |
| 280 R                    | 275 0140 020           | 14 | 180 | 84  | 10 |
| 280 R                    | 275 0150 020           | 15 | 190 | 97  | 10 |
| 280 R                    | 275 0160 020           | 16 | 200 | 105 | 10 |
| 280 R                    | 275 0170 020           | 17 | 210 | 120 | 10 |
| 280 R                    | 275 0180 020           | 18 | 210 | 145 | 10 |
| 280 R                    | 275 0190 020           | 19 | 230 | 160 | 10 |
| 280 R                    | 275 0210 020           | 21 | 240 | 200 | 5  |
| 280 R                    | 275 0220 020           | 22 | 260 | 235 | 5  |
| 280 R                    | 275 0240 020           | 24 | 280 | 275 | 5  |
| 280 R                    | 275 0270 020           | 27 | 300 | 360 | 5  |
| 280 R                    | 275 0280 020           | 28 | 300 | 375 | 5  |
| 280 R                    | 275 0300 020           | 30 | 330 | 450 | 5  |



Ringschlüssel, gerade  
ring spanner, straight

# Schraubenschlüssel Spanners & wrenches

Ring-Maulschlüssel **ENERGY** 

DIN 3113 Form B – ISO 3318

lange Ausführung, Ringsseite 15° gekröpft,

Chrom-Vanadium-Stahl, verchromt, Köpfe geschliffen,

alle mm-Größen mit **ENERGY**-Profil auf der Ringsseite

(bis 41 mm)

Combination spanner **ENERGY** 

DIN 3113 Form B – ISO 3318



long pattern, ring end 15° offset, chrome vanadium

steel, chrome plated, heads smoothly grinded,

**ENERGY** profile at ring end (up to 41 mm)



290 C



| Artikel-Nr.<br>Order-No. | Ident-Nr.<br>Ident-No. | mm | L   |  |  |
|--------------------------|------------------------|----|-----|---|---|
| 290 C                    | 05952                  | 6  | 110 | 21  | 10  |
| 290 C                    | 05962                  | 7  | 120 | 23  | 10  |
| 290 C                    | 05722                  | 8  | 130 | 30  | 10  |
| 290 C                    | 05732                  | 9  | 140 | 36  | 10  |
| 290 C                    | 05742                  | 10 | 150 | 45  | 10  |
| 290 C                    | 05752                  | 11 | 160 | 54  | 10  |
| 290 C                    | 05762                  | 12 | 170 | 62  | 10  |
| 290 C                    | 05772                  | 13 | 175 | 74  | 10  |
| 290 C                    | 05782                  | 14 | 185 | 90  | 10  |
| 290 C                    | 05792                  | 15 | 195 | 101   | 10  |
| 290 C                    | 05802                  | 16 | 210 | 122   | 10  |
| 290 C                    | 05812                  | 17 | 230 | 144   | 10  |
| 290 C                    | 05822                  | 18 | 240 | 155   | 10  |
| 290 C                    | 05832                  | 19 | 250 | 186   | 10  |
| 290 C                    | 05842                  | 20 | 250 | 214   | 10  |
| 290 C                    | 05852                  | 21 | 285 | 276   | 10  |
| 290 C                    | 05862                  | 22 | 285 | 293   | 10  |
| 290 C                    | 05872                  | 23 | 330 | 273   | 5   |
| 290 C                    | 05882                  | 24 | 330 | 392   | 5   |
| 290 C                    | 05892                  | 25 | 355 | 453   | 5   |
| 290 C                    | 05902                  | 26 | 355 | 442   | 5   |
| 290 C                    | 05912                  | 27 | 360 | 486   | 5   |
| 290 C                    | 05922                  | 28 | 360 | 458   | 5   |
| 290 C                    | 05932                  | 30 | 395 | 637   | 5   |
| 290 C                    | 05942                  | 32 | 435 | 755   | 5   |
| 290 C                    | 05702                  | 34 | 435 | 983   | 3   |
| 290 C                    | 05972                  | 36 | 470 | 952   | 3   |
| 290 C                    | 05982                  | 41 | 475 | 1339  | 1   |



vernickelt **ENERGY**

nickel plated **ENERGY**

| Artikel-Nr.<br>Order-No. | Ident-Nr.<br>Ident-No. | mm | L   |  |  |
|--------------------------|------------------------|----|-----|---|---|
| 290 N                    | 05283                  | 46 | 520 | 1752  | 1   |
| 290 N                    | 05293                  | 50 | 560 | 2100  | 1   |
| 290 N                    | 05303                  | 55 | 610 | 2860  | 1   |
| 290 N                    | 05313                  | 60 | 660 | 3420  | 1   |
| 290 N                    | 05523                  | 65 | 710 | 4550  | 1   |
| 290 N                    | 05533                  | 70 | 760 | 5800  | 1   |
| 290 N                    | 05543                  | 75 | 810 | 6650  | 1   |
| 290 N                    | 05553                  | 80 | 860 | 7500  | 1   |

Satz in Karton **ENERGY**

Set in carton **ENERGY**

| Artikel-Nr.<br>Order-No. | Ident-Nr.<br>Ident-No. | Inhalt<br>Content  | mm |  |  |
|--------------------------|------------------------|--|----|---|--|
| 290/8 C                  | 4952                   | 8, 10, 11, 13, 14, 17, 19, 22                                |    | 915   | 1  |
| 290/12 C                 | 4962                   | 8, 9, 10, 11, 12, 13, 14, 15, 17, 19, 21, 22                 |    | 1390  | 1  |
| 290/16 C                 | 4982                   | 8, 9, 10, 11, 12, 13, 14, 15, 17, 19, 21, 22, 24, 27, 30, 32 |    | 3660  | 1  |

290 C







# Schraubenschlüssel Spanners & wrenches

Doppelringschlüsse **ENERGY**   
DIN 837 B – ISO 3318  
gerade, Chrom-Vanadium-Stahl, verchromt,  
Ringe geschliffen, **ENERGY**-Profil

Double ended ring spanner **ENERGY**   
DIN 837 B – ISO 3318  
straight, chrome vanadium steel, chrome plated,  
rings smoothly grinded, **ENERGY**-profile

360 C





| Artikel-Nr.<br>Order-No. | Ident-Nr.<br>Ident-No. |  mm | L   |  |  |
|--------------------------|------------------------|--|-----|---|---|
| 360 C                    | 06521                  | 6 x 7  | 97  | 12  | 10  |
| 360 C                    | 06531                  | 8 x 9  | 115 | 16  | 10  |
| 360 C                    | 06541                  | 8 x 10   | 115 | 19  | 10  |
| 360 C                    | 06551                  | 9 x 11   | 125 | 25  | 10  |
| 360 C                    | 06561                  | 10 x 11  | 125 | 27  | 10  |
| 360 C                    | 06571                  | 10 x 13  | 140 | 33  | 10  |
| 360 C                    | 06591                  | 11 x 13  | 140 | 33  | 10  |
| 360 C                    | 06611                  | 12 x 13  | 140 | 40  | 10  |
| 360 C                    | 06621                  | 12 x 14  | 145 | 40  | 10  |
| 360 C                    | 06601                  | 13 x 14  | 150 | 46  | 10  |
| 360 C                    | 06631                  | 13 x 15  | 155 | 46  | 10  |
| 360 C                    | 06861                  | 13 x 16  | 155 | 46  | 10  |
| 360 C                    | 06641                  | 14 x 15  | 155 | 50  | 10  |
| 360 C                    | 06651                  | 13 x 17  | 170 | 67  | 10  |
| 360 C                    | 06661                  | 14 x 17  | 170 | 65  | 10  |
| 360 C                    | 06671                  | 16 x 17  | 170 | 70  | 10  |
| 360 C                    | 06681                  | 16 x 18  | 170 | 65  | 10  |
| 360 C                    | 06691                  | 17 x 19  | 185 | 84  | 10  |
| 360 C                    | 06701                  | 18 x 19  | 190 | 83  | 10  |
| 360 C                    | 06881                  | 18 x 21  | 200 | 128   | 10  |
| 360 C                    | 06711                  | 19 x 22  | 200 | 124   | 10  |
| 360 C                    | 06721                  | 20 x 22  | 200 | 120   | 10  |
| 360 C                    | 06731                  | 21 x 23  | 215 | 142   | 5   |
| 360 C                    | 06921                  | 21 x 24  | 215 | 144   | 5   |
| 360 C                    | 06741                  | 22 x 24  | 215 | 144   | 5   |
| 360 C                    | 06761                  | 24 x 26  | 255 | 201   | 5   |
| 360 C                    | 06771                  | 24 x 27  | 255 | 199   | 5   |
| 360 C                    | 06781                  | 25 x 28  | 265 | 217   | 5   |
| 360 C                    | 06801                  | 27 x 32  | 280 | 260   | 5   |
| 360 C                    | 06811                  | 30 x 32  | 285 | 292   | 5   |
| 360 C                    | 06941                  | 30 x 34  | 330 | 380   | 5   |
| 360 C                    | 06821                  | 30 x 36  | 330 | 380   | 3   |
| 360 C                    | 06831                  | 32 x 36  | 330 | 427   | 3   |

Satz in Karton **ENERGY**

Set in carton **ENERGY**

360 C

| Artikel-Nr.<br>Order-No. | Ident-Nr.<br>Ident-No. | Inhalt<br>Content  |  mm |  |  |
|--------------------------|------------------------|--|--|---|---|
| 360/8 C                  | 06871                  | 6x7, 8x9, 10x11, 12x13, 14x15, 16x17, 18x19, 20x22                             |  | 420   | 1   |
| 360/12 C                 | 06901                  | 6x7, 8x9, 10x11, 12x13, 14x15, 16x17, 18x19, 20x22, 21x23, 24x27, 25x28, 30x32 |  | 1270  | 1   |



# Schraubenschlüssel Spanners & wrenches

Doppelringschlüssel **ENERGY** 

DIN 838 – ISO 3318

gekröpft, Chrom-Vanadium-Stahl, verchromt, Ringe geschliffen, mm-Größen mit **ENERGY**-Profil



Double ended ring spanner **ENERGY** 

DIN 838 – ISO 3318

offset, chrome vanadium steel, chrome plated, rings smoothly grinded, mm-sizes with **ENERGY**-profil



380 C



| Artikel-Nr.<br>Order-No. | Ident-Nr.<br>Ident-No. | $\updownarrow$ mm |  | L   |  |  |
|--------------------------|------------------------|-------------------|--|-----|---|---|
| 380 C                    | 07301                  | 6 x 7             |  | 175 | 53  | 10  |
| 380 C                    | 07281                  | 7 x 8             |  | 179 | 55  | 10  |
| 380 C                    | 07311                  | 8 x 9             |  | 179 | 70  | 10  |
| 380 C                    | 07321                  | 8 x 10            |  | 185 | 69  | 10  |
| 380 C                    | 07331                  | 9 x 11            |  | 193 | 84  | 10  |
| 380 C                    | 07341                  | 10 x 11           |  | 197 | 84  | 10  |
| 380 C                    | 07361                  | 10 x 13           |  | 220 | 111   | 10  |
| 380 C                    | 07381                  | 11 x 13           |  | 218 | 117   | 10  |
| 380 C                    | 07401                  | 12 x 13           |  | 222 | 113   | 10  |
| 380 C                    | 07411                  | 12 x 14           |  | 225 | 125   | 10  |
| 380 C                    | 07421                  | 13 x 14           |  | 224 | 152   | 10  |
| 380 C                    | 07431                  | 13 x 15           |  | 225 | 161   | 10  |
| 380 C                    | 07441                  | 14 x 15           |  | 230 | 157   | 10  |
| 380 C                    | 07741                  | 13 x 16           |  | 248 | 183   | 10  |
| 380 C                    | 07451                  | 13 x 17           |  | 245 | 186   | 10  |
| 380 C                    | 07461                  | 14 x 17           |  | 248 | 182   | 10  |
| 380 C                    | 07471                  | 16 x 17           |  | 251 | 199   | 10  |
| 380 C                    | 07481                  | 16 x 18           |  | 251 | 211   | 10  |
| 380 C                    | 07491                  | 17 x 19           |  | 290 | 257   | 10  |
| 380 C                    | 07501                  | 18 x 19           |  | 285 | 266   | 10  |
| 380 C                    | 07291                  | 18 x 21           |  | 285 | 322   | 10  |
| 380 C                    | 07511                  | 19 x 22           |  | 297 | 295   | 10  |
| 380 C                    | 07521                  | 20 x 22           |  | 300 | 324   | 10  |
| 380 C                    | 07531                  | 19 x 24           |  | 311 | 350   | 5   |
| 380 C                    | 07541                  | 21 x 23           |  | 315 | 356   | 5   |
| 380 C                    | 07821                  | 21 x 24           |  | 312 | 384   | 5   |
| 380 C                    | 07551                  | 22 x 24           |  | 312 | 379   | 5   |
| 380 C                    | 07561                  | 24 x 26           |  | 335 | 437   | 5   |
| 380 C                    | 07571                  | 24 x 27           |  | 324 | 474   | 5   |
| 380 C                    | 07581                  | 24 x 30           |  | 343 | 587   | 5   |
| 380 C                    | 07591                  | 25 x 28           |  | 340 | 577   | 5   |
| 380 C                    | 07601                  | 27 x 30           |  | 343 | 600   | 5   |
| 380 C                    | 07611                  | 27 x 32           |  | 383 | 639   | 5   |
| 380 C                    | 07621                  | 30 x 32           |  | 383 | 623   | 5   |
| 380 C                    | 07761                  | 30 x 34           |  | 400 | 643   | 3   |
| 380 C                    | 07631                  | 30 x 36           |  | 400 | 810   | 3   |
| 380 C                    | 07831                  | 32 x 34           |  | 395 | 790   | 3   |
| 380 C                    | 07641                  | 32 x 36           |  | 395 | 790   | 3   |
| 380 C                    | 07841                  | 34 x 36           |  | 395 | 862   | 3   |
| 380 C                    | 07651                  | 36 x 41           |  | 445 | 1200  | 3   |
| 380 C                    | 07661                  | 41 x 46           |  | 490 | 1500  | 1   |
| 380 C                    | 07671                  | 46 x 50           |  | 535 | 1900  | 1   |

vernickelt **ENERGY**

nickel plated **ENERGY**



| Artikel-Nr.<br>Order-No. | Ident-Nr.<br>Ident-No. | $\updownarrow$ mm |  | L   |  |  |
|--------------------------|------------------------|-------------------|--|-----|---|---|
| 380 N                    | 07683                  | 55 x 60           |  | 610 | 3775  | 1   |
| 380 N                    | 07693                  | 65 x 70           |  | 685 | 5410  | 1   |
| 380 N                    | 07703                  | 75 x 80           |  | 790 | 7100  | 1   |
| 380 N                    | 07713                  | 85 x 90           |  | 800 | 6800  | 1   |

Amerikanische Zollmaße AF"

ohne **ENERGY**-profil

AF"

without **ENERGY**-profil

| Artikel-Nr.<br>Order-No. | Ident-Nr.<br>Ident-No. | $\updownarrow$ AF"    |  | L   |  |  |
|--------------------------|------------------------|-----------------------|--|-----|---|---|
| 380 C                    | 07851                  | $1/4 \times 5/16$     |  | 153 | 53  | 10  |
| 380 C                    | 07861                  | $5/16 \times 3/8$     |  | 183 | 71  | 10  |
| 380 C                    | 07871                  | $3/8 \times 7/16$     |  | 195 | 80  | 10  |
| 380 C                    | 07881                  | $7/16 \times 1/2$     |  | 194 | 123   | 10  |
| 380 C                    | 07891                  | $1/2 \times 9/16$     |  | 222 | 144   | 10  |
| 380 C                    | 07901                  | $9/16 \times 5/8$     |  | 215 | 182   | 10  |
| 380 C                    | 07911                  | $5/8 \times 11/16$    |  | 252 | 199   | 10  |
| 380 C                    | 07921                  | $5/8 \times 3/4$      |  | 250 | 225   | 10  |
| 380 C                    | 07931                  | $11/16 \times 3/4$    |  | 281 | 257   | 10  |
| 380 C                    | 07941                  | $3/4 \times 7/8$      |  | 229 | 318   | 10  |
| 380 C                    | 07951                  | $13/16 \times 7/8$    |  | 229 | 347   | 10  |
| 380 C                    | 07961                  | $15/16 \times 1$      |  | 331 | 459   | 5   |
| 380 C                    | 07971                  | $1 \times 1 1/8$      |  | 345 | 583   | 5   |
| 380 C                    | 07981                  | $1 1/16 \times 1 1/4$ |  | 364 | 649   | 5   |
| 380 C                    | 07991                  | $1 1/4 \times 1 7/16$ |  | 409 | 824   | 1   |
| 380 C                    | 08001                  | $1 7/16 \times 1 5/8$ |  | 440 | 1240  | 1   |

# Schraubenschlüssel Spanners & wrenches

Satz in Karton **ENERGY**

Set in carton **ENERGY**

380 C

| Artikel-Nr.<br>Order-No. | Ident-Nr.<br>Ident-No. | Inhalt<br>Content  | $\updownarrow$ mm |      |   |
|--------------------------|------------------------|--|-------------------|------|---|
| 380/6 C                  | 07751                  | 6x7, 8x9, 10x11, 12x13, 14x15, 16x17   |                   | 675  | I |
| 380/8 C                  | 07771                  | 6x7, 8x9, 10x11, 12x13, 14x15, 16x17, 18x19, 20x22                             |                   | 1400 | I |
| 380/10 C                 | 07791                  | 6x7, 8x9, 10x11, 12x13, 14x15, 16x17, 18x19, 20x22, 21x23, 24x27               |                   | 2095 | I |
| 380/12 C                 | 07801                  | 6x7, 8x9, 10x11, 12x13, 14x15, 16x17, 18x19, 20x22, 21x23, 24x27, 25x28, 30x32 |                   | 3295 | I |



Amerikanische Zollmaße AF"  
ohne **ENERGY**-profil

AF"  
without **ENERGY**-profil

| Artikel-Nr.<br>Order-No. | Ident-Nr.<br>Ident-No. | Inhalt<br>Content  | $\updownarrow$ AF" |      |   |
|--------------------------|------------------------|--|--------------------|------|---|
| 380/6 C                  | 08031                  | $1/4 \times 5/16$ , $3/8 \times 7/16$ , $1/2 \times 9/16$ , $5/8 \times 3/4$ , $13/16 \times 7/8$ , $15/16 \times 1$   |                    | 1310 | I |
| 380/8 C                  | 08041                  | $1/4 \times 5/16$ , $5/16 \times 3/8$ , $7/16 \times 1/2$ , $9/16 \times 5/8$ , $11/16 \times 3/4$ , $13/16 \times 7/8$ , $15/16 \times 1$ , $1 1/16 \times 1 1/4$   |                    | 2140 | I |
| 380/12 C                 | 08051                  | $1/4 \times 5/16$ , $5/16 \times 3/8$ , $3/8 \times 7/16$ , $7/16 \times 1/2$ , $1/2 \times 9/16$ , $9/16 \times 5/8$ , $11/16 \times 3/4$ , $13/16 \times 7/8$ , $15/16 \times 1$ , $1 1/16 \times 1 1/4$ , $1 1/4 \times 1 7/16$ , $1 7/16 \times 1 5/8$ |                    | 4430 | I |

Satz in Sichtkarton **ENERGY**

Set in display carton **ENERGY**

380 C

| Artikel-Nr.<br>Order-No. | Ident-Nr.<br>Ident-No. | Inhalt<br>Content                                  | $\updownarrow$ mm |      |   |
|--------------------------|------------------------|--|-------------------|------|---|
| 380/8 C                  | 380 0083 010           | 6x7, 8x9, 10x11, 12x13, 14x15, 16x17, 18x19, 20x22 |                   | 1350 | I |



Ringschlüssel, gekröpft  
ring spanner, offset

# Schraubenschlüssel Spanners & wrenches

## Doppel-Gelenksteckschlüssel

Chrom-Vanadium-Stahl, verchromt, Köpfe poliert

## Double ended swivel head spanner

chrome vanadium steel, chrome plated, heads polished

350 C



| Artikel-Nr.<br>Order-No. | Ident-Nr.<br>Ident-No. | mm      | L   |     |    |
|--------------------------|------------------------|---------|-----|-----|----|
| 350 C                    | 06291                  | 8 x 9   | 175 | 65  | 10 |
| 350 C                    | 06301                  | 10 x 11 | 195 | 100 | 10 |
| 350 C                    | 06311                  | 12 x 13 | 210 | 145 | 10 |
| 350 C                    | 06321                  | 13 x 17 | 225 | 210 | 10 |
| 350 C                    | 06331                  | 14 x 15 | 225 | 210 | 10 |
| 350 C                    | 06341                  | 16 x 17 | 245 | 270 | 10 |
| 350 C                    | 06271                  | 16 x 18 | 245 | 270 | 10 |
| 350 C                    | 06351                  | 17 x 19 | 280 | 360 | 10 |
| 350 C                    | 06361                  | 18 x 19 | 260 | 360 | 10 |

Satz in Karton

Set in carton

| Artikel-Nr.<br>Order-No. | Ident-Nr.<br>Ident-No. | Inhalt<br>Content                       | mm |      |   |
|--------------------------|------------------------|---|----|------|---|
| 350/6 C                  | 06410                  | 8x9, 10x11, 12x13, 14x15, 16x18, 17x19, |    | 1150 | 1 |



350 C

## Offener Ringschlüssel

DIN 3118

für Überwurfmutter und Rohrleitungsverschraubungen, Chrom-Vanadium-Stahl, verchromt, Köpfe geschliffen

## Open ended ring spanner

DIN 3118

for all union nuts and tube lines, chrome vanadium steel, chrome plated, heads smoothly grinded

370 C



| Artikel-Nr.<br>Order-No. | Ident-Nr.<br>Ident-No. | mm      | L   |     |   |
|--------------------------|------------------------|---------|-----|-----|---|
| 370 C                    | 07182                  | 8 x 10  | 150 | 55  | 5 |
| 370 C                    | 07192                  | 9 x 11  | 150 | 55  | 5 |
| 370 C                    | 07202                  | 10 x 11 | 155 | 65  | 5 |
| 370 C                    | 07201                  | 11 x 13 | 175 | 80  | 5 |
| 370 C                    | 07210                  | 12 x 14 | 175 | 80  | 5 |
| 370 C                    | 07213                  | 13 x 15 | 175 | 90  | 5 |
| 370 C                    | 07232                  | 14 x 17 | 200 | 135 | 5 |
| 370 C                    | 07231                  | 16 x 18 | 215 | 175 | 5 |
| 370 C                    | 07221                  | 17 x 19 | 215 | 175 | 5 |
| 370 C                    | 07242                  | 19 x 22 | 215 | 210 | 5 |
| 370 C                    | 07251                  | 22 x 24 | 240 | 240 | 1 |
| 370 C                    | 07262                  | 24 x 27 | 255 | 290 | 1 |
| 370 C                    | 07271                  | 30 x 32 | 280 | 320 | 1 |

## Doppelringschlüssel

für Außen-TORX-Schrauben, Chrom-Vanadium-Stahl, verchromt, Köpfe poliert

## Double ended ring spanner

for exterior TORX head screws, chrome vanadium steel, chrome plated, heads polished

390 C



| Artikel-Nr.<br>Order-No. | Ident-Nr.<br>Ident-No. | Nr.<br>No.  | in mm   | L   |     |   |
|--------------------------|------------------------|-------------|---------|-----|-----|---|
| 390 C                    | 07092                  | E 6 x E 8   | 8 x 10  | 115 | 14  | 1 |
| 390 C                    | 07102                  | E 10 x E 12 | 9 x 11  | 144 | 25  | 1 |
| 390 C                    | 07112                  | E 14 x E 18 | 10 x 11 | 179 | 55  | 1 |
| 390 C                    | 07122                  | E 20 x E 24 | 30 x 32 | 226 | 155 | 1 |

Satz in Karton

Set in carton

| Artikel-Nr.<br>Order-No. | Ident-Nr.<br>Ident-No. | Inhalt<br>Content                        | mm |     |   |
|--------------------------|------------------------|--|----|-----|---|
| 390/4 C                  | 07132                  | E6 x E8, E10 x E12, E14 x E18, E20 x E24 |    | 250 | 1 |



390 C

# Schraubenschlüssel Spanners & wrenches



## Starter- und Blockschlüssel **ENERGY**

Chrom-Vanadium-Stahl, verchromt, Ringe geschliffen,  
mm-Größen mit **ENERGY**-Profil

## Starter and block spanner **ENERGY**

chrome vanadium steel, chrome plated, rings smoothly  
grinded, mm-sizes with **ENERGY**-profile





| Artikel-Nr.<br>Order-No. | Ident-Nr.<br>Ident-No. | $\updownarrow$ mm |  | L   |  |  |
|--------------------------|------------------------|-------------------|--|-----|---|---|
| 420 C                    | 08431                  | 11 x 13           |  | 151 | 77  | 10  |
| 420 C                    | 08441                  | 12 x 13           |  | 150 | 77  | 10  |
| 420 C                    | 08451                  | 13 x 15           |  | 186 | 101   | 10  |
| 420 C                    | 08461                  | 14 x 17           |  | 186 | 155   | 10  |
| 420 C                    | 08471                  | 19 x 22           |  | 228 | 261   | 10  |

## Amerikanische Zollmaße AF"

ohne **ENERGY**-profil

## AF"

without **ENERGY**-profile

| Artikel-Nr.<br>Order-No. | Ident-Nr.<br>Ident-No. | $\updownarrow$ AF" |  | L   |  |  |
|--------------------------|------------------------|--------------------|--|-----|---|---|
| 420 C                    | 08481                  | 7/16 x 1/2         |  | 144 | 77  | 10  |
| 420 C                    | 08491                  | 1/2 x 9/16         |  | 150 | 99  | 10  |
| 420 C                    | 08501                  | 9/16 x 5/8         |  | 188 | 153   | 10  |
| 420 C                    | 08511                  | 3/4 x 7/8          |  | 230 | 279   | 1   |



## Doppel-Steckschlüssel

massiv, Chrom-Vanadium-Stahl, geschmiedet und  
durchgehend gebohrt, verchromt,  
Verwendung mit Drehstift

## Double ended box wrench

solid pattern, chrome vanadium steel, forged and  
bored through, chrome plated, use with tommy bar





| Artikel-Nr.<br>Order-No. | Ident-Nr.<br>Ident-No. | $\updownarrow$ mm | Drehstift Ø<br>tommy bar | L   |  |  |
|--------------------------|------------------------|-------------------|--------------------------|-----|--|--|
| 1130                     | 15111                  | 6 x 7             | 3                        | 100 | 30   | 10   |
| 1130                     | 15121                  | 8 x 9             | 3                        | 108 | 50   | 10   |
| 1130                     | 15131                  | 10 x 11           | 5                        | 116 | 70   | 10   |
| 1130                     | 15141                  | 12 x 13           | 5                        | 124 | 100  | 10   |
| 1130                     | 15151                  | 14 x 15           | 6                        | 132 | 120  | 10   |
| 1130                     | 15161                  | 16 x 17           | 8                        | 140 | 160  | 10   |
| 1130                     | 15171                  | 17 x 19           | 8                        | 148 | 195  | 10   |
| 1130                     | 15181                  | 18 x 19           | 8                        | 148 | 195  | 10   |
| 1130                     | 15191                  | 20 x 22           | 10                       | 156 | 255  | 10   |
| 1130                     | 15201                  | 21 x 23           | 10                       | 163 | 300  | 5  |
| 1130                     | 15211                  | 24 x 27           | 10                       | 173 | 390  | 5  |
| 1130                     | 15221                  | 25 x 28           | 10                       | 182 | 460  | 5  |
| 1130                     | 15231                  | 30 x 32           | 12                       | 200 | 620  | 5  |

## Satz in Karton

mit Drehstiften 1085/1 - 1090/3 - 1090/5

## Set in carton

with tommy bar 1085/1 - 1090/3 - 1090/5

| Artikel-Nr.<br>Order-No. | Ident-Nr.<br>Ident-No. | Inhalt<br>Content  | $\updownarrow$ mm |  |  |
|--------------------------|------------------------|--|-------------------|---|---|
| 1130 / 8                 | 15281                  | 6x7, 8x9, 10x11, 12x13, 14x15, 16x17, 18x19, 20x22                             |                   | 1250  | 1   |
| 1130 / 12                | 15291                  | 6x7, 8x9, 10x11, 12x13, 14x15, 16x17, 18x19, 20x22, 21x23, 24x27, 25x28, 30x32 |                   | 3200  | 1   |





# Schraubenschlüssel Spanners & wrenches

## Rohrsteckschlüssel

DIN 896 Form B – ISO 2236 / ISO 1085

doppelseitig, aus nahtlos kaltgezogenem Präzisions-Stahlrohr, gehärtet, vernickelt, Verwendung mit Drehstift



## Tubular box wrench

DIN 896 Form B – ISO 2236 / ISO 1085

Double ended, seamless drawn steel tube, hardened, nickel plated, use with tommy bar



1080 N



| Artikel-Nr.<br>Order-No. | Ident-Nr.<br>Ident-No. |  mm | Drehstift Ø<br>tommy bar | L   |  |  |
|--------------------------|------------------------|--|--------------------------|-----|---|---|
| 1080 N                   | 14313                  | 6 x 7  | 5                        | 100 | 30  | 10  |
| 1080 N                   | 14303                  | 7 x 8  | 5                        | 100 | 30  | 10  |
| 1080 N                   | 14323                  | 8 x 9  | 5                        | 105 | 35  | 10  |
| 1080 N                   | 14333                  | 8 x 10   | 5                        | 120 | 45  | 10  |
| 1080 N                   | 14343                  | 9 x 10   | 6                        | 120 | 45  | 10  |
| 1080 N                   | 14353                  | 9 x 11   | 6                        | 120 | 55  | 10  |
| 1080 N                   | 14363                  | 10 x 11  | 6                        | 120 | 55  | 10  |
| 1080 N                   | 14373                  | 10 x 13  | 6                        | 120 | 80  | 10  |
| 1080 N                   | 14383                  | 11 x 13  | 6                        | 135 | 85  | 10  |
| 1080 N                   | 14403                  | 12 x 13  | 6                        | 135 | 85  | 10  |
| 1080 N                   | 14413                  | 12 x 14  | 6                        | 140 | 85  | 10  |
| 1080 N                   | 14423                  | 13 x 15  | 8                        | 140 | 90  | 10  |
| 1080 N                   | 14093                  | 13 x 16  | 8                        | 140 | 90  | 10  |
| 1080 N                   | 14433                  | 14 x 15  | 8                        | 140 | 90  | 10  |
| 1080 N                   | 14443                  | 13 x 17  | 8                        | 150 | 130   | 10  |
| 1080 N                   | 14453                  | 14 x 17  | 8                        | 150 | 130   | 10  |
| 1080 N                   | 14463                  | 16 x 17  | 10                       | 150 | 130   | 10  |
| 1080 N                   | 14103                  | 16 x 18  | 10                       | 150 | 135   | 10  |
| 1080 N                   | 14473                  | 17 x 19  | 10                       | 160 | 195   | 10  |
| 1080 N                   | 14483                  | 18 x 19  | 10                       | 160 | 195   | 10  |
| 1080 N                   | 14493                  | 19 x 22  | 12                       | 165 | 220   | 10  |
| 1080 N                   | 14503                  | 20 x 22  | 12                       | 165 | 220   | 10  |
| 1080 N                   | 14513                  | 21 x 23  | 12                       | 170 | 225   | 5   |
| 1080 N                   | 14523                  | 19 x 24  | 12                       | 185 | 300   | 5   |
| 1080 N                   | 14533                  | 22 x 24  | 14                       | 185 | 300   | 5   |
| 1080 N                   | 14543                  | 24 x 26  | 14                       | 185 | 300   | 5   |
| 1080 N                   | 14553                  | 24 x 27  | 14                       | 185 | 300   | 5   |
| 1080 N                   | 14563                  | 24 x 30  | 14                       | 205 | 380   | 5   |
| 1080 N                   | 14573                  | 25 x 28  | 14                       | 205 | 350   | 5   |
| 1080 N                   | 14583                  | 27 x 30  | 16                       | 205 | 380   | 5   |
| 1080 N                   | 14603                  | 30 x 32  | 16                       | 205 | 410   | 5   |
| 1080 N                   | 14113                  | 30 x 34  | 16                       | 205 | 500   | 1   |
| 1080 N                   | 14613                  | 30 x 36  | 16                       | 220 | 530   | 1   |
| 1080 N                   | 14623                  | 32 x 36  | 16                       | 220 | 530   | 1   |
| 1080 N                   | 14633                  | 36 x 41  | 18                       | 220 | 700   | 1   |
| 1080 N                   | 14643                  | 41 x 46  | 18                       | 245 | 800   | 1   |
| 1080 N                   | 14123                  | 46 x 50  | 18                       | 250 | 1250  | 1   |
| 1080 N                   | 14133                  | 50 x 55  | 18                       | 250 | 1670  | 1   |

Satz in Karton  
ohne Drehstift

Set in carton  
without tommy bar

| Artikel-Nr.<br>Order-No. | Ident-Nr.<br>Ident-No. | Inhalt<br>Content  |  mm |  |  |
|--------------------------|------------------------|--|--|---|---|
| 1080 / 8                 | 14673                  | 6x7, 8x9, 10x11, 12x13, 14x15, 16x17, 18x19, 20x22                             |  | 890   | 1   |
| 1080 / 12                | 14683                  | 6x7, 8x9, 10x11, 12x13, 14x15, 16x17, 18x19, 20x22, 21x23, 24x27, 25x28, 30x32 |  | 2500  | 1   |

1080



# Schraubenschlüssel Spanners & wrenches

Stufendrehstift  
vernickelt

Tommy bar  
nickel plated



I085

| Artikel-Nr.<br>Order-No. | Ident-Nr.<br>Ident-No. |  | Ø                   | L   |     |   |
|--------------------------|------------------------|--|---------------------|-----|-----|---|
| I085/1                   | I4703                  |  | 6, 8, 10, 12, 14    | 250 | 240 | 5 |
| I085/2                   | I4704                  |  | 3, 3.5, 4.5, 5.5, 6 | 180 | 35  | 5 |
| I085/3                   | I4705                  |  | 7, 8, 9, 10, 12, 13 | 280 | 260 | 5 |

Drehstift  
DIN 900 A  
phosphatiert

Tommy bar  
DIN 900 A  
phosphatized



I090 PH

| Artikel-Nr.<br>Order-No. | Ident-Nr.<br>Ident-No. |  | Ø  | L   |      |   |
|--------------------------|------------------------|--|----|-----|------|---|
| I090 PH                  | I4734                  |  | 3  | 110 | 5    | 5 |
| I090 PH                  | I4744                  |  | 5  | 125 | 15   | 5 |
| I090 PH                  | I4754                  |  | 6  | 160 | 35   | 5 |
| I090 PH                  | I4764                  |  | 8  | 180 | 70   | 5 |
| I090 PH                  | I4774                  |  | 10 | 200 | 115  | 5 |
| I090 PH                  | I4784                  |  | 12 | 250 | 210  | 5 |
| I090 PH                  | I4794                  |  | 14 | 320 | 380  | 5 |
| I090 PH                  | I4804                  |  | 16 | 400 | 620  | 1 |
| I090 PH                  | I4814                  |  | 18 | 500 | 1000 | 1 |

Dreikant-Rohrsteckschlüssel  
DIN 22417

aus nahtlos kaltgezogenem Präzisions-Stahlrohr,  
mit durchgestecktem, beweglichem Quergriff, verzinkt

Three-square tubular wrench  
DIN 22417

made of seamless drawn steel tube with movable  
T-handle, zinc plated



I100 Z

| Artikel-Nr.<br>Order-No. | Ident-Nr.<br>Ident-No. | Inhalt<br>Content |  | L   |     |    |
|--------------------------|------------------------|-------------------|--|-----|-----|----|
| I100 Z                   | I4839                  | M 4               |  | 90  | 25  | 10 |
| I100 Z                   | I4849                  | M 5               |  | 100 | 35  | 10 |
| I100 Z                   | I4859                  | M 6               |  | 110 | 65  | 5  |
| I100 Z                   | I4869                  | M 8               |  | 125 | 85  | 5  |
| I100 Z                   | I4879                  | M 10              |  | 140 | 170 | 5  |
| I100 Z                   | I4889                  | M 12              |  | 162 | 250 | 1  |
| I100 Z                   | I4899                  | M 16              |  | 180 | 450 | 1  |

## Phosphatierte Werkzeuge

### Was heißt „phosphatieren“?

Unter „phosphatieren“ verstehen wir die Behandlung von Metalloberflächen mit speziellen phosphathaltigen Lösungen. Wir verwenden ein hochwertiges Zinkphosphat, das eine besonders feinkristalline Oberflächenstruktur erzeugt. Metalloberfläche und Phosphatschicht gehen dabei eine dauerhafte, auf mechanischem Wege untrennbare Verbindung ein. Durch weitere Bäder nach dem Phosphatieren werden die feinen Poren gesättigt und ein dauerhafter Korrosionsschutz erreicht.

### Warum „phosphatierte Werkzeuge“?

- Das „Phosphatieren“ ist ein umweltschonender Produktionsvorgang.
- Phosphatierte Oberflächen sind dauerhaft gegen Korrosion geschützt.
- Die Phosphatierung ist widerstandsfähig gegen Schlägeinwirkung. Keine Gefahr des Abplatzens oder Abblätterns. Deshalb verwenden wir phosphatierte Werkzeuge bei Kraft-Einsätzen und hochwertigen Schlagschlüsseln.
- Unsere phosphatierten Werkzeuge sind bei gleicher Material- und Verarbeitungsqualität deutlich preiswerter als die entsprechenden Artikel in verchromter Ausführung.

## Phosphatized tools

### What means „phosphatized“?

„Phosphatizing“ means treatment of metal surfaces with special phosphate liquids. We use a high-quality zinc phosphate that produces a specially fine crystalline surface structure. Metal surface and phosphate undergo a chemical metallurgical bonding which is unseparable by mechanical means. By further bathes after phosphatizing the fine pores are saturated and a permanent protection against corrosion is reached.

### Why use phosphatized tools?

- phosphatizing is an environmental protecting production method.
- phosphated surfaces are permanently protected against corrosion.
- phosphated surfaces are resistant against impacts. No danger of chipping or peeling off. That's why we use this surface treatment on impact sockets and high-quality slugging spanners.
- prices of our phosphatized tools are considerably lower than the corresponding items in chrome plated version, but offering the same quality in material and workmanship.



Phosphatierte Werkzeuge  
phosphated tools

# Schraubenschlüssel Spanners & wrenches

Doppelmaulschlüssel  
DIN 3110 – ISO 3318/ISO 1085  
Chrom-Vanadium-Stahl, phosphatiert,  
Maulstellung 15°

Double open ended spanner  
DIN 3110 – ISO 3318/ISO 1085  
chrome vanadium steel, phosphatized,  
position of open ends 15°

100 PH



| Artikel-Nr.<br>Order-No. | Ident-Nr.<br>Ident-No. | mm      | L   |     |    |
|--------------------------|------------------------|---------|-----|-----|----|
| 100 PH                   | 00054                  | 4 x 5   | 110 | 16  | 10 |
| 100 PH                   | 00094                  | 6 x 7   | 123 | 22  | 10 |
| 100 PH                   | 00104                  | 7 x 8   | 132 | 30  | 10 |
| 100 PH                   | 00124                  | 8 x 9   | 143 | 30  | 10 |
| 100 PH                   | 00134                  | 8 x 10  | 143 | 30  | 10 |
| 100 PH                   | 00154                  | 9 x 11  | 157 | 46  | 10 |
| 100 PH                   | 00164                  | 10 x 11 | 157 | 48  | 10 |
| 100 PH                   | 00174                  | 10 x 12 | 157 | 45  | 10 |
| 100 PH                   | 00184                  | 10 x 13 | 171 | 64  | 10 |
| 100 PH                   | 00194                  | 11 x 13 | 171 | 69  | 10 |
| 100 PH                   | 00204                  | 12 x 13 | 172 | 64  | 10 |
| 100 PH                   | 00224                  | 12 x 14 | 180 | 69  | 10 |
| 100 PH                   | 00234                  | 13 x 14 | 180 | 81  | 10 |
| 100 PH                   | 00244                  | 13 x 15 | 190 | 88  | 10 |
| 100 PH                   | 00254                  | 14 x 15 | 190 | 88  | 10 |
| 100 PH                   | 00034                  | 13 x 16 | 190 | 100 | 10 |
| 100 PH                   | 00264                  | 13 x 17 | 190 | 96  | 10 |
| 100 PH                   | 00274                  | 14 x 17 | 190 | 97  | 10 |
| 100 PH                   | 00284                  | 16 x 17 | 205 | 124 | 10 |
| 100 PH                   | 00534                  | 16 x 18 | 220 | 110 | 10 |
| 100 PH                   | 00294                  | 17 x 19 | 220 | 156 | 10 |
| 100 PH                   | 00304                  | 18 x 19 | 220 | 156 | 10 |
| 100 PH                   | 00074                  | 18 x 21 | 235 | 214 | 10 |
| 100 PH                   | 00324                  | 19 x 22 | 235 | 209 | 10 |
| 100 PH                   | 00334                  | 20 x 22 | 237 | 200 | 10 |
| 100 PH                   | 00344                  | 21 x 23 | 250 | 235 | 5  |
| 100 PH                   | 00354                  | 19 x 24 | 245 | 240 | 5  |
| 100 PH                   | 00514                  | 21 x 24 | 250 | 230 | 5  |
| 100 PH                   | 00364                  | 22 x 24 | 250 | 244 | 5  |
| 100 PH                   | 00384                  | 24 x 26 | 270 | 320 | 5  |
| 100 PH                   | 00394                  | 24 x 27 | 270 | 295 | 5  |
| 100 PH                   | 00404                  | 24 x 30 | 285 | 360 | 5  |
| 100 PH                   | 00414                  | 25 x 28 | 280 | 370 | 5  |
| 100 PH                   | 00434                  | 27 x 30 | 295 | 466 | 5  |
| 100 PH                   | 00444                  | 27 x 32 | 302 | 468 | 5  |
| 100 PH                   | 00454                  | 30 x 32 | 295 | 492 | 5  |
| 100 PH                   | 00614                  | 30 x 34 | 320 | 477 | 3  |
| 100 PH                   | 00464                  | 30 x 36 | 320 | 526 | 3  |
| 100 PH                   | 00644                  | 32 x 34 | 323 | 600 | 3  |
| 100 PH                   | 00474                  | 32 x 36 | 323 | 600 | 3  |
| 100 PH                   | 00624                  | 34 x 36 | 323 | 586 | 3  |
| 100 PH                   | 00484                  | 36 x 41 | 350 | 723 | 3  |

# Schraubenschlüssel Spanners & wrenches

## Ring-Maulschlüssel **ENERGY**

DIN 3113 Form A – ISO 3318

kurze Ausführung, Ringseite 15° abgewinkelt,  
Chrom-Vanadium-Stahl, phosphatiert, Ringseite mit  
**ENERGY**-Profil

## Combination spanner **ENERGY**

DIN 3113 Form A – ISO 3318

short pattern, ring end 15° angled, chrome vanadium  
steel, phosphatized, **ENERGY**-profile at ring end

280 PH



| Artikel-Nr.<br>Order-No. | Ident-Nr.<br>Ident-No. | mm | L   |     |    |
|--------------------------|------------------------|----|-----|-----|----|
| 280 PH                   | 05014                  | 6  | 100 | 14  | 10 |
| 280 PH                   | 05024                  | 7  | 110 | 16  | 10 |
| 280 PH                   | 05034                  | 8  | 120 | 26  | 10 |
| 280 PH                   | 05044                  | 9  | 130 | 32  | 10 |
| 280 PH                   | 05054                  | 10 | 140 | 39  | 10 |
| 280 PH                   | 05064                  | 11 | 150 | 49  | 10 |
| 280 PH                   | 05074                  | 12 | 160 | 58  | 10 |
| 280 PH                   | 05084                  | 13 | 170 | 89  | 10 |
| 280 PH                   | 05094                  | 14 | 180 | 84  | 10 |
| 280 PH                   | 05104                  | 15 | 190 | 97  | 10 |
| 280 PH                   | 05114                  | 16 | 200 | 105 | 10 |
| 280 PH                   | 05124                  | 17 | 210 | 130 | 10 |
| 280 PH                   | 05134                  | 18 | 210 | 125 | 10 |
| 280 PH                   | 05144                  | 19 | 230 | 180 | 10 |
| 280 PH                   | 05154                  | 20 | 230 | 188 | 10 |
| 280 PH                   | 05164                  | 21 | 240 | 203 | 10 |
| 280 PH                   | 05174                  | 22 | 260 | 249 | 10 |
| 280 PH                   | 05184                  | 23 | 260 | 215 | 5  |
| 280 PH                   | 05194                  | 24 | 280 | 280 | 5  |
| 280 PH                   | 05204                  | 25 | 280 | 260 | 5  |
| 280 PH                   | 05214                  | 26 | 300 | 302 | 5  |
| 280 PH                   | 05224                  | 27 | 300 | 380 | 5  |
| 280 PH                   | 05234                  | 28 | 300 | 357 | 5  |
| 280 PH                   | 05244                  | 30 | 332 | 472 | 5  |
| 280 PH                   | 05254                  | 32 | 360 | 555 | 5  |
| 280 PH                   | 04994                  | 34 | 380 | 690 | 3  |
| 280 PH                   | 05264                  | 36 | 380 | 670 | 3  |

## Ring-Maulschlüssel **ENERGY**

DIN 3113 Form B – ISO 3318

Lange Ausführung, Ringseite 15° gekröpft,  
Chrom-Vanadium-Stahl, phosphatiert, **ENERGY**-Profil  
auf der Ringseite

## Combination spanner **ENERGY**

DIN 3113 Form B – ISO 3318

long pattern, ring end 15° offset, chrome vanadium  
steel, phosphatized, **ENERGY**-profile at ring end

290 PH



| Artikel-Nr.<br>Order-No. | Ident-Nr.<br>Ident-No. | mm | L   |      |    |
|--------------------------|------------------------|----|-----|------|----|
| 290 PH                   | 05954                  | 6  | 110 | 21   | 10 |
| 290 PH                   | 05964                  | 7  | 120 | 23   | 10 |
| 290 PH                   | 05724                  | 8  | 130 | 30   | 10 |
| 290 PH                   | 05734                  | 9  | 140 | 36   | 10 |
| 290 PH                   | 05744                  | 10 | 150 | 45   | 10 |
| 290 PH                   | 05754                  | 11 | 160 | 54   | 10 |
| 290 PH                   | 05764                  | 12 | 170 | 62   | 10 |
| 290 PH                   | 05774                  | 13 | 175 | 74   | 10 |
| 290 PH                   | 05784                  | 14 | 185 | 90   | 10 |
| 290 PH                   | 05794                  | 15 | 195 | 101  | 10 |
| 290 PH                   | 05804                  | 16 | 210 | 122  | 10 |
| 290 PH                   | 05814                  | 17 | 230 | 144  | 10 |
| 290 PH                   | 05824                  | 18 | 240 | 155  | 10 |
| 290 PH                   | 05834                  | 19 | 250 | 186  | 10 |
| 290 PH                   | 05844                  | 20 | 250 | 214  | 10 |
| 290 PH                   | 05854                  | 21 | 285 | 276  | 10 |
| 290 PH                   | 05864                  | 22 | 285 | 293  | 10 |
| 290 PH                   | 05874                  | 23 | 330 | 273  | 5  |
| 290 PH                   | 05884                  | 24 | 330 | 392  | 5  |
| 290 PH                   | 05894                  | 25 | 355 | 453  | 5  |
| 290 PH                   | 05904                  | 26 | 355 | 442  | 5  |
| 290 PH                   | 05914                  | 27 | 360 | 486  | 5  |
| 290 PH                   | 05924                  | 28 | 361 | 458  | 5  |
| 290 PH                   | 05934                  | 30 | 395 | 637  | 5  |
| 290 PH                   | 05944                  | 32 | 435 | 755  | 5  |
| 290 PH                   | 05704                  | 34 | 435 | 983  | 3  |
| 290 PH                   | 05974                  | 36 | 470 | 952  | 3  |
| 290 PH                   | 05984                  | 41 | 475 | 1339 | 1  |



# Schraubenschlüssel Spanners & wrenches

Doppel-Ringschlüssel **ENERGY**

DIN 838 – ISO 3318

gekröpft, Chrom-Vanadium-Stahl, phosphatiert,

**ENERGY**-Profil

Double ended ring spanner **ENERGY**



DIN 838 – ISO 3318

offset, chrome vanadium steel, phosphatized,

**ENERGY** profile

380 PH



| Artikel-Nr.<br>Order-No. | Ident-Nr.<br>Ident-No. | mm      |  | L   |  |  |
|--------------------------|------------------------|---------|--|-----|---|---|
| 380 PH                   | 07304                  | 6 x 7   |  | 175 | 53  | 10  |
| 380 PH                   | 07284                  | 7 x 8   |  | 179 | 55  | 10  |
| 380 PH                   | 07314                  | 8 x 9   |  | 179 | 70  | 10  |
| 380 PH                   | 07324                  | 8 x 10  |  | 185 | 69  | 10  |
| 380 PH                   | 07334                  | 9 x 11  |  | 193 | 84  | 10  |
| 380 PH                   | 07344                  | 10 x 11 |  | 197 | 84  | 10  |
| 380 PH                   | 07364                  | 10 x 13 |  | 220 | 111   | 10  |
| 380 PH                   | 07384                  | 11 x 13 |  | 218 | 117   | 10  |
| 380 PH                   | 07404                  | 12 x 13 |  | 222 | 113   | 10  |
| 380 PH                   | 07414                  | 12 x 14 |  | 225 | 125   | 10  |
| 380 PH                   | 07424                  | 13 x 14 |  | 224 | 152   | 10  |
| 380 PH                   | 07434                  | 13 x 15 |  | 225 | 161   | 10  |
| 380 PH                   | 07444                  | 14 x 15 |  | 230 | 157   | 10  |
| 380 PH                   | 07744                  | 13 x 16 |  | 248 | 183   | 10  |
| 380 PH                   | 07454                  | 13 x 17 |  | 245 | 186   | 10  |
| 380 PH                   | 07464                  | 14 x 17 |  | 248 | 182   | 10  |
| 380 PH                   | 07474                  | 16 x 17 |  | 251 | 199   | 10  |
| 380 PH                   | 07484                  | 16 x 18 |  | 251 | 211   | 10  |
| 380 PH                   | 07494                  | 17 x 19 |  | 290 | 257   | 10  |
| 380 PH                   | 07504                  | 18 x 19 |  | 285 | 266   | 10  |
| 380 PH                   | 07294                  | 18 x 21 |  | 285 | 322   | 10  |
| 380 PH                   | 07514                  | 19 x 22 |  | 297 | 295   | 10  |
| 380 PH                   | 07524                  | 20 x 22 |  | 300 | 324   | 10  |
| 380 PH                   | 07534                  | 19 x 24 |  | 311 | 350   | 5   |
| 380 PH                   | 07544                  | 21 x 23 |  | 315 | 356   | 5   |
| 380 PH                   | 07824                  | 21 x 24 |  | 312 | 384   | 5   |
| 380 PH                   | 07554                  | 22 x 24 |  | 312 | 379   | 5   |
| 380 PH                   | 07564                  | 24 x 26 |  | 335 | 437   | 5   |
| 380 PH                   | 07574                  | 24 x 27 |  | 324 | 474   | 5   |
| 380 PH                   | 07584                  | 24 x 30 |  | 343 | 587   | 5   |
| 380 PH                   | 07594                  | 25 x 28 |  | 340 | 577   | 5   |
| 380 PH                   | 07604                  | 27 x 30 |  | 343 | 600   | 5   |
| 380 PH                   | 07614                  | 27 x 32 |  | 383 | 630   | 5   |
| 380 PH                   | 07624                  | 30 x 32 |  | 383 | 623   | 5   |
| 380 PH                   | 07764                  | 30 x 34 |  | 400 | 643   | 3   |
| 380 PH                   | 07634                  | 30 x 36 |  | 400 | 810   | 3   |
| 380 PH                   | 07834                  | 32 x 34 |  | 395 | 790   | 3   |
| 380 PH                   | 07644                  | 32 x 36 |  | 395 | 790   | 3   |
| 380 PH                   | 07844                  | 34 x 36 |  | 395 | 862   | 3   |
| 380 PH                   | 07654                  | 36 x 41 |  | 445 | 1200  | 3   |

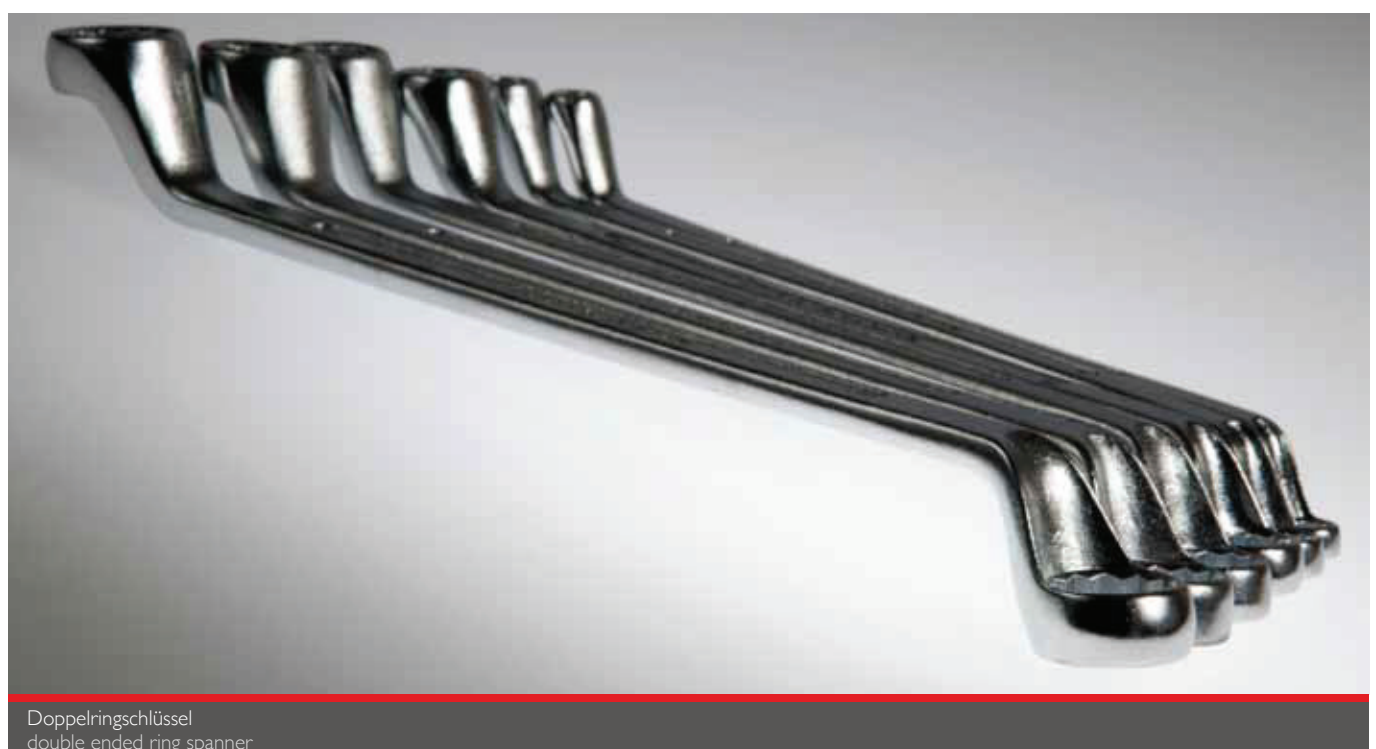

Doppelringschlüssel  
double ended ring spanner

# Schraubenschlüssel Spanners & wrenches

Doppelringschlüssel **ENERGY**

DIN 837 B – ISO 3318

gerade, Chrom-Vanadium-Stahl, phosphatiert,

**ENERGY**-Profil

Double ended ring spanner **ENERGY**

DIN 837 B – ISO 3318

straight, chrome vanadium steel, phosphatized,

**ENERGY** profile

360 PH



| Artikel-Nr.<br>Order-No. | Ident-Nr.<br>Ident-No. | mm      |  | L   |     |    |
|--------------------------|------------------------|---------|--|-----|-----|----|
| 360 PH                   | 06524                  | 6 x 7   |  | 97  | 12  | 10 |
| 360 PH                   | 06534                  | 8 x 9   |  | 115 | 16  | 10 |
| 360 PH                   | 06544                  | 8 x 10  |  | 115 | 19  | 10 |
| 360 PH                   | 06554                  | 9 x 11  |  | 125 | 25  | 10 |
| 360 PH                   | 06564                  | 10 x 11 |  | 125 | 27  | 10 |
| 360 PH                   | 06574                  | 10 x 13 |  | 140 | 33  | 10 |
| 360 PH                   | 06594                  | 11 x 13 |  | 140 | 33  | 10 |
| 360 PH                   | 06614                  | 12 x 13 |  | 140 | 41  | 10 |
| 360 PH                   | 06624                  | 12 x 14 |  | 145 | 40  | 10 |
| 360 PH                   | 06604                  | 13 x 14 |  | 155 | 46  | 10 |
| 360 PH                   | 06634                  | 13 x 15 |  | 155 | 46  | 10 |
| 360 PH                   | 06864                  | 13 x 16 |  | 155 | 46  | 10 |
| 360 PH                   | 06644                  | 14 x 15 |  | 155 | 50  | 10 |
| 360 PH                   | 06654                  | 13 x 17 |  | 170 | 67  | 10 |
| 360 PH                   | 06664                  | 14 x 17 |  | 170 | 65  | 10 |
| 360 PH                   | 06674                  | 16 x 17 |  | 170 | 70  | 10 |
| 360 PH                   | 06684                  | 16 x 18 |  | 170 | 65  | 10 |
| 360 PH                   | 06694                  | 17 x 19 |  | 185 | 84  | 10 |
| 360 PH                   | 06704                  | 18 x 19 |  | 190 | 83  | 10 |
| 360 PH                   | 06884                  | 18 x 21 |  | 200 | 128 | 10 |
| 360 PH                   | 06714                  | 19 x 22 |  | 200 | 124 | 10 |
| 360 PH                   | 06724                  | 20 x 22 |  | 200 | 120 | 10 |
| 360 PH                   | 06734                  | 21 x 23 |  | 215 | 142 | 5  |
| 360 PH                   | 06924                  | 21 x 24 |  | 215 | 144 | 5  |
| 360 PH                   | 06744                  | 22 x 24 |  | 215 | 144 | 5  |
| 360 PH                   | 06764                  | 24 x 26 |  | 255 | 201 | 5  |
| 360 PH                   | 06774                  | 24 x 27 |  | 255 | 199 | 5  |
| 360 PH                   | 06784                  | 25 x 28 |  | 265 | 217 | 5  |
| 360 PH                   | 06804                  | 27 x 32 |  | 280 | 260 | 5  |
| 360 PH                   | 06814                  | 30 x 32 |  | 285 | 292 | 5  |
| 360 PH                   | 06944                  | 30 x 34 |  | 330 | 380 | 5  |
| 360 PH                   | 06824                  | 30 x 36 |  | 330 | 380 | 3  |
| 360 PH                   | 06834                  | 32 x 36 |  | 330 | 427 | 3  |
| 360 PH                   | 07034                  | 34 x 36 |  | 330 | 382 | 1  |

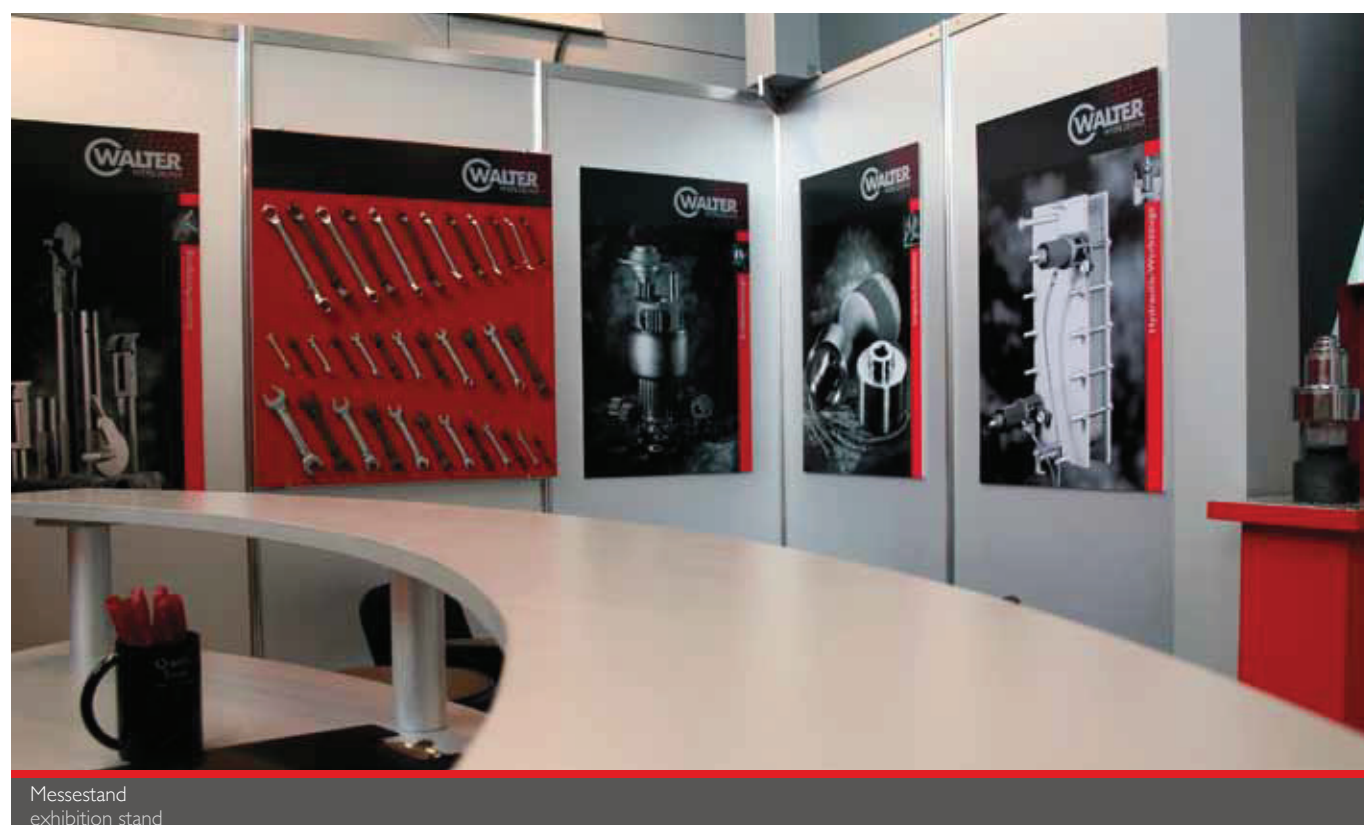

Messestand  
exhibition stand

# Schraubenschlüssel Spanners & wrenches

## Einmaulschlüssel

DIN 894 – ISO 3318

Spezial-Stahl, Maulstellung 15°.

bis Größe 38 mm: phosphatiert (PH)

ab Größe 41 mm: stahlgrau (SG)

## Single open ended spanner

DIN 894 – ISO 3318

special steel, position of open end 15°.

up to size 38 mm: phosphatized (PH)

from size 41 mm: steel grey (SG)

**I 80 PH**



| Artikel-Nr.<br>Order-No. | Ident-Nr.<br>Ident-No. | ↕ mm | L   | ⚖   | 📄  |
|--------------------------|------------------------|------|-----|-----|----|
| 180 PH                   | 02954                  | 6    | 77  | 10  | 10 |
| 180 PH                   | 02964                  | 7    | 78  | 10  | 10 |
| 180 PH                   | 02974                  | 8    | 95  | 20  | 10 |
| 180 PH                   | 02984                  | 9    | 100 | 20  | 10 |
| 180 PH                   | 02994                  | 10   | 105 | 25  | 10 |
| 180 PH                   | 03004                  | 11   | 125 | 34  | 10 |
| 180 PH                   | 03014                  | 12   | 125 | 36  | 10 |
| 180 PH                   | 03024                  | 13   | 135 | 44  | 10 |
| 180 PH                   | 03034                  | 14   | 140 | 52  | 10 |
| 180 PH                   | 03044                  | 15   | 140 | 49  | 10 |
| 180 PH                   | 02914                  | 16   | 140 | 50  | 10 |
| 180 PH                   | 03054                  | 17   | 160 | 57  | 10 |
| 180 PH                   | 03064                  | 18   | 160 | 65  | 10 |
| 180 PH                   | 03074                  | 19   | 170 | 86  | 10 |
| 180 PH                   | 03344                  | 21   | 195 | 116 | 10 |
| 180 PH                   | 03084                  | 22   | 195 | 118 | 10 |
| 180 PH                   | 03094                  | 24   | 205 | 145 | 5  |
| 180 PH                   | 03104                  | 27   | 235 | 225 | 5  |
| 180 PH                   | 03114                  | 30   | 260 | 285 | 5  |
| 180 PH                   | 03124                  | 32   | 265 | 330 | 5  |
| 180 PH                   | 03354                  | 34   | 275 | 326 | 3  |
| 180 PH                   | 03134                  | 36   | 300 | 428 | 3  |
| 180 PH                   | 02924                  | 38   | 300 | 424 | 3  |

Stahlgrau

steel grey

| Artikel-Nr.<br>Order-No. | Ident-Nr.<br>Ident-No. | ↕ mm | L    | ⚖    | 📄 |
|--------------------------|------------------------|------|------|------|---|
| 180 SG                   | 03145                  | 41   | 345  | 545  | 3 |
| 180 SG                   | 03155                  | 46   | 375  | 800  | 3 |
| 180 SG                   | 03165                  | 50   | 410  | 980  | 1 |
| 180 SG                   | 03175                  | 55   | 455  | 1260 | 1 |
| 180 SG                   | 03185                  | 60   | 490  | 1650 | 1 |
| 180 SG                   | 03195                  | 65   | 575  | 1895 | 1 |
| 180 SG                   | 03205                  | 70   | 570  | 2340 | 1 |
| 180 SG                   | 03215                  | 75   | 610  | 2610 | 1 |
| 180 SG                   | 03225                  | 80   | 645  | 3330 | 1 |
| 180 SG                   | 03235                  | 85   | 690  | 3490 | 1 |
| 180 SG                   | 03245                  | 90   | 850  | 3455 | 1 |
| 180 SG                   | 03255                  | 95   | 850  | 6050 | 1 |
| 180 SG                   | 03265                  | 100  | 1000 | 5740 | 1 |
| 180 SG                   | 03275                  | 105  | 1000 | 8430 | 1 |
| 180 SG                   | 03285                  | 110  | 1000 | 8430 | 1 |
| 180 SG                   | 03295                  | 115  | 1000 | 7940 | 1 |
| 180 SG                   | 03305                  | 120  | 1000 | 8000 | 1 |
| 180 SG                   | 03315                  | 125  | 1000 | 8255 | 1 |
| 180 SG                   | 03325                  | 130  | 1000 | 7790 | 1 |
| 180 SG                   | 03335                  | 135  | 1000 | 7725 | 1 |

# Schraubenschlüssel Spanners & wrenches

Doppelmaulschlüssel  
DIN 895 – ISO 3318/ISO 1085  
Spezial-Stahl, Maulstellung 15°  
bis Größe 34x36: phosphatiert (PH)  
ab Größe 36x41: stahlgrau (SG)

Double open ended spanner  
DIN 895 – ISO 3318/ISO 1085  
special steel, position of open ends 15°,  
up to size 34x36: phosphatized (PH)  
from size 36x41: steel grey (SG)

200 PH



| Artikel-Nr.<br>Order-No. | Ident-Nr.<br>Ident-No. | mm      | L   |     |    |
|--------------------------|------------------------|---------|-----|-----|----|
| 200 PH                   | 03404                  | 6 x 7   | 95  | 12  | 10 |
| 200 PH                   | 03414                  | 7 x 8   | 108 | 20  | 10 |
| 200 PH                   | 03424                  | 7 x 9   | 110 | 20  | 10 |
| 200 PH                   | 03434                  | 8 x 9   | 117 | 28  | 10 |
| 200 PH                   | 03444                  | 8 x 10  | 115 | 28  | 10 |
| 200 PH                   | 03474                  | 9 x 10  | 123 | 31  | 10 |
| 200 PH                   | 03484                  | 9 x 11  | 122 | 28  | 10 |
| 200 PH                   | 03494                  | 10 x 11 | 122 | 31  | 10 |
| 200 PH                   | 03804                  | 10 x 12 | 125 | 35  | 10 |
| 200 PH                   | 03504                  | 10 x 13 | 123 | 45  | 10 |
| 200 PH                   | 03514                  | 10 x 14 | 140 | 54  | 10 |
| 200 PH                   | 03524                  | 11 x 13 | 140 | 54  | 10 |
| 200 PH                   | 03534                  | 11 x 14 | 140 | 54  | 10 |
| 200 PH                   | 03544                  | 12 x 13 | 142 | 50  | 10 |
| 200 PH                   | 03554                  | 12 x 14 | 142 | 55  | 10 |
| 200 PH                   | 03564                  | 13 x 14 | 160 | 53  | 10 |
| 200 PH                   | 03574                  | 13 x 15 | 160 | 69  | 10 |
| 200 PH                   | 03364                  | 13 x 16 | 160 | 74  | 10 |
| 200 PH                   | 03584                  | 13 x 17 | 160 | 74  | 10 |
| 200 PH                   | 03814                  | 14 x 15 | 160 | 74  | 10 |
| 200 PH                   | 03594                  | 14 x 17 | 160 | 66  | 10 |
| 200 PH                   | 03824                  | 16 x 17 | 170 | 70  | 10 |
| 200 PH                   | 03374                  | 16 x 18 | 170 | 104 | 10 |
| 200 PH                   | 03604                  | 17 x 19 | 193 | 99  | 10 |
| 200 PH                   | 03614                  | 17 x 22 | 170 | 143 | 10 |
| 200 PH                   | 03934                  | 18 x 19 | 195 | 99  | 10 |
| 200 PH                   | 03384                  | 18 x 21 | 195 | 123 | 10 |
| 200 PH                   | 03624                  | 19 x 22 | 205 | 140 | 10 |
| 200 PH                   | 03634                  | 19 x 24 | 195 | 191 | 10 |
| 200 PH                   | 03944                  | 20 x 22 | 206 | 119 | 10 |
| 200 PH                   | 03954                  | 21 x 23 | 205 | 208 | 5  |
| 200 PH                   | 03834                  | 21 x 24 | 220 | 208 | 5  |
| 200 PH                   | 03644                  | 22 x 24 | 235 | 216 | 5  |
| 200 PH                   | 03654                  | 22 x 27 | 244 | 250 | 5  |
| 200 PH                   | 03664                  | 24 x 27 | 265 | 257 | 5  |
| 200 PH                   | 03674                  | 24 x 30 | 244 | 283 | 5  |
| 200 PH                   | 03964                  | 25 x 28 | 270 | 257 | 5  |
| 200 PH                   | 03794                  | 27 x 30 | 270 | 360 | 5  |
| 200 PH                   | 03684                  | 27 x 32 | 273 | 408 | 5  |
| 200 PH                   | 03694                  | 30 x 32 | 305 | 450 | 5  |
| 200 PH                   | 03844                  | 30 x 34 | 305 | 453 | 5  |
| 200 PH                   | 03704                  | 30 x 36 | 305 | 528 | 1  |
| 200 PH                   | 03714                  | 32 x 36 | 305 | 534 | 1  |
| 200 PH                   | 03924                  | 34 x 36 | 305 | 537 | 1  |

Stahlgrau

steel grey

| Artikel-Nr.<br>Order-No. | Ident-Nr.<br>Ident-No. | mm      | L   |      |   |
|--------------------------|------------------------|---------|-----|------|---|
| 200 SG                   | 03725                  | 36 X 41 | 340 | 705  | 1 |
| 200 SG                   | 03735                  | 41 X 46 | 380 | 985  | 1 |
| 200 SG                   | 03745                  | 46 X 50 | 420 | 1170 | 1 |
| 200 SG                   | 03755                  | 50 X 55 | 460 | 1530 | 1 |
| 200 SG                   | 03765                  | 55 X 60 | 500 | 1645 | 1 |
| 200 SG                   | 03775                  | 65 X 70 | 580 | 2865 | 1 |
| 200 SG                   | 03785                  | 75 X 80 | 660 | 3960 | 1 |

# Schraubenschlüssel Spanners & wrenches

Hakenschlüssel mit Nase  
DIN 1810 Form A  
für Nutmütern nach DIN 1804,  
Spezial-Stahl, angelassen, schwarz

Hook wrenches with nose  
DIN 1810 Form A  
for slotted nuts as per DIN 1804,  
special steel, tempered, black

260 S



| Artikel-Nr.<br>Order-No. | Ident-Nr.<br>Ident-No. | mm      | L   |      |    |
|--------------------------|------------------------|---------|-----|------|----|
| 260 S                    | 04534                  | 12/ 14  | 110 | 25   | 10 |
| 260 S                    | 04544                  | 16/ 20  | 110 | 25   | 10 |
| 260 S                    | 04554                  | 25/ 28  | 136 | 45   | 10 |
| 260 S                    | 04564                  | 30/ 32  | 136 | 50   | 10 |
| 260 S                    | 04574                  | 34/ 36  | 170 | 90   | 10 |
| 260 S                    | 04584                  | 40/ 42  | 170 | 90   | 10 |
| 260 S                    | 04594                  | 45/ 50  | 206 | 155  | 10 |
| 260 S                    | 04604                  | 52/ 55  | 206 | 160  | 10 |
| 260 S                    | 04614                  | 58/ 62  | 242 | 255  | 10 |
| 260 S                    | 04624                  | 68/ 75  | 242 | 255  | 10 |
| 260 S                    | 04634                  | 80/ 90  | 280 | 410  | 10 |
| 260 S                    | 04644                  | 95/100  | 280 | 385  | 10 |
| 260 S                    | 04654                  | 110/115 | 335 | 745  | I  |
| 260 S                    | 04664                  | 120/130 | 335 | 720  | I  |
| 260 S                    | 04674                  | 135/145 | 385 | 1000 | I  |
| 260 S                    | 04684                  | 155/165 | 385 | 965  | I  |
| 260 S                    | 04694                  | 180/195 | 470 | 1580 | I  |
| 260 S                    | 04704                  | 205/220 | 470 | 1580 | I  |
| 260 S                    | 04714                  | 230/245 | 560 | 2250 | I  |
| 260 S                    | 04724                  | 260/270 | 568 | 2250 | I  |
| 260 S                    | 04734                  | 280/300 | 680 | 5000 | I  |
| 260 S                    | 04744                  | 380/400 | 770 | 6700 | I  |

Hakenschlüssel mit Zapfen  
DIN 1810 Form B  
für Kreuzlochmütern gemäß DIN 1816,  
Spezial-Stahl, angelassen, schwarz

Hook wrench with pin  
DIN 1810 Form B  
for round nuts with pin holes as per DIN 1816,  
special steel, tempered, black

265 S



| Artikel-Nr.<br>Order-No. | Ident-Nr.<br>Ident-No. | mm      | L   |      |    |
|--------------------------|------------------------|---------|-----|------|----|
| 265 S                    | 04526                  | 12/ 14  | 110 | 25   | 10 |
| 265 S                    | 04536                  | 16/ 18  | 110 | 40   | 10 |
| 265 S                    | 04546                  | 20/ 22  | 110 | 40   | 10 |
| 265 S                    | 04556                  | 25/ 28  | 136 | 55   | 10 |
| 265 S                    | 04566                  | 30/ 32  | 136 | 55   | 10 |
| 265 S                    | 04576                  | 34/ 36  | 170 | 100  | 10 |
| 265 S                    | 04586                  | 40/ 42  | 170 | 100  | 10 |
| 265 S                    | 04596                  | 45/ 50  | 205 | 165  | 10 |
| 265 S                    | 04606                  | 52/ 55  | 205 | 165  | 10 |
| 265 S                    | 04616                  | 58/ 62  | 240 | 270  | 10 |
| 265 S                    | 04626                  | 68/ 75  | 240 | 270  | 10 |
| 265 S                    | 04636                  | 80/ 90  | 280 | 410  | 10 |
| 265 S                    | 04646                  | 95/100  | 280 | 410  | 10 |
| 265 S                    | 04656                  | 110/115 | 335 | 780  | I  |
| 265 S                    | 04666                  | 120/130 | 335 | 780  | I  |
| 265 S                    | 04676                  | 135/145 | 380 | 1000 | I  |
| 265 S                    | 04686                  | 155/165 | 380 | 1000 | I  |
| 265 S                    | 04696                  | 180/195 | 470 | 1580 | I  |
| 265 S                    | 04706                  | 205/220 | 470 | 1580 | I  |
| 265 S                    | 04716                  | 230/245 | 560 | 2250 | I  |
| 265 S                    | 04726                  | 260/270 | 570 | 2250 | I  |



# Schraubenschlüssel Spanners & wrenches

## Aufsteck-Ringschlüssel

gekröpft, für schwere Zug-Beanspruchung, Chrom-Vanadium-Stahl, verchromt, zur Verwendung mit Aufsteckrohren No. 440 I bis IV (bitte extra bestellen)

| Artikel-Nr.<br>Order-No. | Ident-Nr.<br>Ident-No. | mm  | Rohr Ø<br>Tube Ø | D   | h  | H  | L   | L2  |      |   |
|--------------------------|------------------------|-----|------------------|-----|----|----|-----|-----|------|---|
| 440                      | 08551                  | 24  | I                | 38  | 17 | 30 | 180 | 85  | 365  | I |
| 440                      | 08561                  | 27  | I                | 41  | 17 | 32 | 190 | 90  | 400  | I |
| 440                      | 08571                  | 30  | I                | 48  | 18 | 34 | 200 | 95  | 490  | I |
| 440                      | 08581                  | 32  | II               | 49  | 18 | 34 | 235 | 116 | 730  | I |
| 440                      | 08591                  | 36  | II               | 55  | 20 | 36 | 245 | 120 | 770  | I |
| 440                      | 08601                  | 41  | II               | 62  | 22 | 40 | 265 | 129 | 950  | I |
| 440                      | 08611                  | 46  | III              | 69  | 23 | 40 | 280 | 129 | 1300 | I |
| 440                      | 08621                  | 50  | III              | 76  | 26 | 43 | 290 | 129 | 1450 | I |
| 440                      | 08631                  | 55  | III              | 81  | 28 | 46 | 300 | 136 | 1750 | I |
| 440                      | 08641                  | 60  | IV               | 90  | 31 | 49 | 345 | 156 | 2300 | I |
| 440                      | 08651                  | 65  | IV               | 98  | 33 | 53 | 355 | 158 | 2600 | I |
| 440                      | 08661                  | 70  | IV               | 105 | 36 | 55 | 365 | 160 | 2850 | I |
| 440                      | 08671                  | 75  | IV               | 110 | 38 | 58 | 375 | 161 | 2900 | I |
| 440                      | 08681                  | 80  | IV               | 125 | 41 | 59 | 385 | 170 | 3900 | I |
| 440                      | 08691                  | 85  | IV               | 125 | 41 | 59 | 385 | 170 | 4000 | I |
| 440                      | 08701                  | 90  | IV               | 140 | 45 | 63 | 410 | 170 | 4800 | I |
| 440                      | 08711                  | 95  | IV               | 140 | 45 | 63 | 410 | 170 | 4800 | I |
| 440                      | 08721                  | 100 | IV               | 143 | 45 | 63 | 412 | 170 | 4900 | I |
| 440                      | 08731                  | 105 | IV               | 146 | 45 | 63 | 415 | 170 | 4900 | I |

## Heavy duty single ended offset ring spanner

chrome vanadium steel, chrome plated, to be used with tubes No. 440 I to IV (please, order separately)

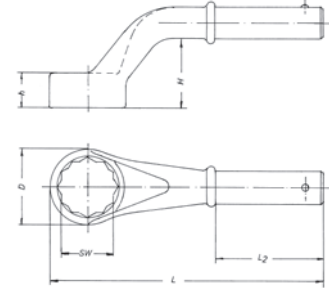

440

## Aufsteckrohr

für Ringschlüssel, Stahlrohr, verchromt

## Tube

for above spanners, steel tube, chrome plated

| Artikel-Nr.<br>Order-No. | Ident-Nr.<br>Ident-No. | Nr.<br>No. | Rohr Ø<br>Tube Ø | L   |      |
|--------------------------|------------------------|------------|------------------|-----|------|
| 440 R                    | 08751                  | I          | 25               | 460 | 600  |
| 440 R                    | 08761                  | II         | 27               | 610 | 1100 |
| 440 R                    | 08771                  | III        | 32               | 760 | 2100 |
| 440 R                    | 08781                  | IV         | 38               | 860 | 2900 |



440 R

## Ringschlüssel

DIN 3111

gerade, Spezial-Stahl, stahlgrau (SG)

## Ring spanner

DIN 3111

straight, special steel, steel grey (SG)

| Artikel-Nr.<br>Order-No. | Ident-Nr.<br>Ident-No. | mm | L   |      |   |
|--------------------------|------------------------|----|-----|------|---|
| 460 SG                   | 09005                  | 13 | 140 | 70   | I |
| 460 SG                   | 09015                  | 14 | 140 | 70   | I |
| 460 SG                   | 09025                  | 17 | 155 | 100  | I |
| 460 SG                   | 09035                  | 19 | 170 | 110  | I |
| 460 SG                   | 09045                  | 22 | 190 | 150  | I |
| 460 SG                   | 09055                  | 24 | 215 | 200  | I |
| 460 SG                   | 09065                  | 27 | 230 | 250  | I |
| 460 SG                   | 09075                  | 30 | 255 | 320  | I |
| 460 SG                   | 09085                  | 32 | 265 | 360  | I |
| 460 SG                   | 09095                  | 36 | 295 | 520  | I |
| 460 SG                   | 09105                  | 41 | 330 | 780  | I |
| 460 SG                   | 09115                  | 46 | 365 | 920  | I |
| 460 SG                   | 09125                  | 50 | 400 | 1250 | I |
| 460 SG                   | 09135                  | 55 | 445 | 1500 | I |
| 460 SG                   | 09145                  | 60 | 475 | 1900 | I |
| 460 SG                   | 09155                  | 65 | 510 | 2400 | I |
| 460 SG                   | 09165                  | 70 | 555 | 2700 | I |
| 460 SG                   | 09175                  | 75 | 590 | 3500 | I |
| 460 SG                   | 09185                  | 80 | 620 | 4100 | I |
| 460 SG                   | 09195                  | 85 | 665 | 4700 | I |
| 460 SG                   | 09205                  | 90 | 700 | 5300 | I |
| 460 SG                   | 09215                  | 95 | 700 | 5800 | I |



460 SG

# Schraubenschlüssel Spanners & wrenches

Schlag-Ringschlüssel 

Freimaßtoleranz nach DIN 7168B

für schwerste Beanspruchung, geeignet für tieferliegende Schrauben, Chrom-Vanadium-Stahl, phosphatiert



Slugging ring spanner 

tolerance as per DIN 7168B

for highest requirements, suited for deeper seated bolts, chrome vanadium steel, phosphatized

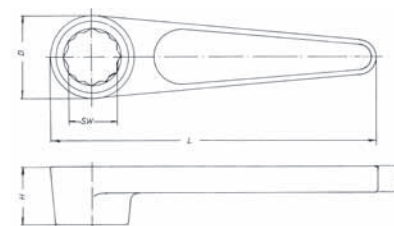
480 PH



| Artikel-Nr.<br>Order-No. | Ident-Nr.<br>Ident-No. | $\varnothing$ mm | D   | H   | b  | L    |  |  |
|--------------------------|------------------------|------------------|-----|-----|----|------|---|---|
| 480 PH                   | 09247                  | 19               | 37  | 21  | 10 | 390  | 700   | I   |
| 480 PH                   | 09257                  | 22               | 37  | 21  | 10 | 390  | 700   | I   |
| 480 PH                   | 09267                  | 24               | 45  | 25  | 10 | 400  | 750   | I   |
| 480 PH                   | 09277                  | 27               | 45  | 25  | 10 | 400  | 750   | I   |
| 480 PH                   | 09287                  | 30               | 50  | 30  | 12 | 410  | 1100  | I   |
| 480 PH                   | 09297                  | 32               | 50  | 30  | 12 | 410  | 1100  | I   |
| 480 PH                   | 09307                  | 36               | 59  | 34  | 13 | 425  | 1400  | I   |
| 480 PH                   | 09317                  | 41               | 67  | 41  | 16 | 475  | 2500  | I   |
| 480 PH                   | 09327                  | 46               | 76  | 47  | 17 | 510  | 2900  | I   |
| 480 PH                   | 09337                  | 50               | 81  | 49  | 20 | 550  | 3700  | I   |
| 480 PH                   | 09347                  | 55               | 87  | 52  | 16 | 560  | 4000  | I   |
| 480 PH                   | 09357                  | 60               | 96  | 56  | 17 | 660  | 5200  | I   |
| 480 PH                   | 09367                  | 65               | 100 | 62  | 19 | 690  | 6400  | I   |
| 480 PH                   | 09377                  | 70               | 104 | 70  | 20 | 700  | 7500  | I   |
| 480 PH                   | 09387                  | 75               | 110 | 72  | 20 | 700  | 8300  | I   |
| 480 PH                   | 09397                  | 80               | 115 | 75  | 22 | 700  | 9700  | I   |
| 480 PH                   | 09407                  | 85               | 125 | 75  | 22 | 750  | 11000   | I   |
| 480 PH                   | 09417                  | 90               | 136 | 80  | 23 | 750  | 13600   | I   |
| 480 PH                   | 09427                  | 95               | 143 | 82  | 23 | 800  | 15000   | I   |
| 480 PH                   | 09437                  | 100              | 150 | 90  | 24 | 850  | 16800   | I   |
| 480 PH                   | 09447                  | 105              | 157 | 95  | 25 | 900  | 18800   | I   |
| 480 PH                   | 09457                  | 110              | 165 | 100 | 25 | 950  | 20500   | I   |
| 480 PH                   | 09467                  | 115              | 173 | 100 | 26 | 1000 | 23500   | I   |
| 480 PH                   | 09477                  | 120              | 180 | 110 | 26 | 1000 | 25600   | I   |



Messestand  
exhibition stand

# Schraubenschlüssel Spanners & wrenches

Schlag-Maulschlüssel  
DIN 133  
Spezial-Stahl, stahlgrau (SG)  
Zwischengrößen auf Anfrage

Open jaw slugging wrench  
DIN 133  
special steel, steel grey (SG)  
special sizes on request

520 SG

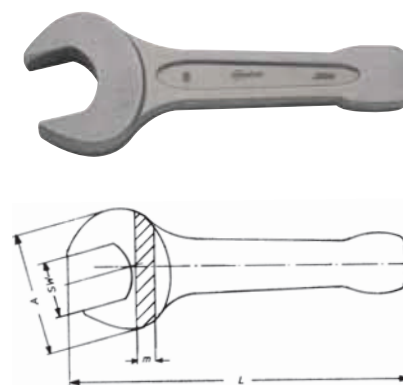

| Artikel-Nr.<br>Order-No. | Ident-Nr.<br>Ident-No. | mm  | Ident-Nr.<br>Ident-No. | AF"                             | A   | m  | L   |       |   |
|--------------------------|------------------------|-----|------------------------|---------------------------------|-----|----|-----|-------|---|
| 520 SG                   | 09505                  | 24  |                        |                                 | 56  | 16 | 180 | 400   | I |
| 520 SG                   | 09515                  | 27  | 09516                  | 1 <sup>1</sup> / <sub>16</sub>  | 56  | 16 | 180 | 400   | I |
| 520 SG                   | 09525                  | 30  | 09517                  | 1 <sup>1</sup> / <sub>8</sub>   | 62  | 17 | 190 | 500   | I |
| 520 SG                   | 09535                  | 32  | 09526                  | 1 <sup>3</sup> / <sub>16</sub>  | 62  | 17 | 190 | 500   | I |
| 520 SG                   |                        |     | 09536                  | 1 <sup>1</sup> / <sub>4</sub>   | 62  | 17 | 190 | 500   | I |
| 520 SG                   | 09545                  | 36  | 09537                  | 1 <sup>5</sup> / <sub>16</sub>  | 76  | 18 | 215 | 550   | I |
| 520 SG                   |                        |     | 09546                  | 1 <sup>3</sup> / <sub>8</sub>   | 76  | 18 | 215 | 550   | I |
| 520 SG                   |                        |     | 09547                  | 1 <sup>7</sup> / <sub>16</sub>  | 76  | 18 | 215 | 550   | I |
| 520 SG                   | 09555                  | 41  | 09548                  | 1 <sup>1</sup> / <sub>2</sub>   | 86  | 19 | 235 | 900   | I |
| 520 SG                   |                        |     | 09556                  | 1 <sup>9</sup> / <sub>16</sub>  | 86  | 19 | 235 | 900   | I |
| 520 SG                   |                        |     | 09557                  | 1 <sup>5</sup> / <sub>8</sub>   | 86  | 19 | 235 | 900   | I |
| 520 SG                   | 09565                  | 46  | 09558                  | 1 <sup>11</sup> / <sub>16</sub> | 98  | 20 | 255 | 1200  | I |
| 520 SG                   |                        |     | 09566                  | 1 <sup>3</sup> / <sub>4</sub>   | 98  | 20 | 255 | 1200  | I |
| 520 SG                   |                        |     | 09567                  | 1 <sup>13</sup> / <sub>16</sub> | 98  | 20 | 255 | 1200  | I |
| 520 SG                   | 09575                  | 50  | 09568                  | 1 <sup>7</sup> / <sub>8</sub>   | 105 | 21 | 275 | 1500  | I |
| 520 SG                   |                        |     | 09576                  | 1 <sup>15</sup> / <sub>16</sub> | 105 | 21 | 275 | 1500  | I |
| 520 SG                   |                        |     | 09577                  | 2                               | 105 | 21 | 275 | 1500  | I |
| 520 SG                   | 09585                  | 55  | 09578                  | 2 <sup>1</sup> / <sub>16</sub>  | 116 | 23 | 300 | 1900  | I |
| 520 SG                   |                        |     | 09586                  | 2 <sup>1</sup> / <sub>8</sub>   | 116 | 23 | 300 | 1900  | I |
| 520 SG                   |                        |     | 09587                  | 2 <sup>3</sup> / <sub>16</sub>  | 116 | 23 | 300 | 1900  | I |
| 520 SG                   | 09595                  | 60  | 09588                  | 2 <sup>1</sup> / <sub>4</sub>   | 128 | 25 | 320 | 2600  | I |
| 520 SG                   |                        |     | 09596                  | 2 <sup>5</sup> / <sub>16</sub>  | 128 | 25 | 320 | 2600  | I |
| 520 SG                   |                        |     | 09597                  | 2 <sup>3</sup> / <sub>8</sub>   | 128 | 25 | 320 | 2600  | I |
| 520 SG                   | 09605                  | 65  | 09598                  | 2 <sup>7</sup> / <sub>16</sub>  | 138 | 27 | 340 | 3400  | I |
| 520 SG                   |                        |     | 09606                  | 2 <sup>1</sup> / <sub>2</sub>   | 138 | 27 | 340 | 3400  | I |
| 520 SG                   |                        |     | 09607                  | 2 <sup>9</sup> / <sub>16</sub>  | 138 | 27 | 340 | 3400  | I |
| 520 SG                   | 09615                  | 70  | 09608                  | 2 <sup>5</sup> / <sub>8</sub>   | 154 | 30 | 375 | 4400  | I |
| 520 SG                   | 09625                  | 75  | 09616                  | 2 <sup>3</sup> / <sub>4</sub>   | 154 | 30 | 375 | 4400  | I |
| 520 SG                   |                        |     | 09617                  | 2 <sup>13</sup> / <sub>16</sub> | 154 | 30 | 375 | 4400  | I |
| 520 SG                   |                        |     | 09618                  | 2 <sup>7</sup> / <sub>8</sub>   | 154 | 30 | 375 | 4300  | I |
| 520 SG                   |                        |     | 09626                  | 2 <sup>15</sup> / <sub>16</sub> | 154 | 30 | 375 | 4300  | I |
| 520 SG                   | 09635                  | 80  | 09627                  | 3                               | 174 | 34 | 410 | 6300  | I |
| 520 SG                   | 09645                  | 85  | 09636                  | 3 <sup>1</sup> / <sub>8</sub>   | 174 | 34 | 410 | 6300  | I |
| 520 SG                   |                        |     | 09637                  | 3 <sup>1</sup> / <sub>4</sub>   | 174 | 34 | 410 | 6200  | I |
| 520 SG                   | 09655                  | 90  | 09646                  | 3 <sup>3</sup> / <sub>8</sub>   | 194 | 38 | 445 | 7300  | I |
| 520 SG                   | 09665                  | 95  | 09656                  | 3 <sup>1</sup> / <sub>2</sub>   | 194 | 38 | 445 | 7300  | I |
| 520 SG                   |                        |     | 09657                  | 3 <sup>5</sup> / <sub>8</sub>   | 194 | 38 | 445 | 7100  | I |
| 520 SG                   | 09675                  | 100 | 09666                  | 3 <sup>3</sup> / <sub>4</sub>   | 215 | 44 | 485 | 12200 | I |
| 520 SG                   | 09685                  | 105 | 09676                  | 3 <sup>7</sup> / <sub>8</sub>   | 215 | 44 | 485 | 12200 | I |
| 520 SG                   |                        |     | 09677                  | 4                               | 215 | 44 | 485 | 11900 | I |
| 520 SG                   | 09695                  | 110 | 09686                  | 4 <sup>1</sup> / <sub>8</sub>   | 235 | 47 | 510 | 13500 | I |
| 520 SG                   | 09705                  | 115 | 09696                  | 4 <sup>1</sup> / <sub>4</sub>   | 235 | 47 | 510 | 13200 | I |
| 520 SG                   | 09715                  | 120 | 09706                  | 4 <sup>1</sup> / <sub>2</sub>   | 255 | 50 | 545 | 15500 | I |
| 520 SG                   | 09725                  | 125 | 09716                  | 4 <sup>3</sup> / <sub>4</sub>   | 255 | 50 | 545 | 15200 | I |
| 520 SG                   | 09735                  | 130 | 09726                  | 5                               | 275 | 55 | 575 | 19300 | I |
| 520 SG                   | 09745                  | 135 |                        |                                 | 275 | 55 | 575 | 19000 | I |
| 520 SG                   | 09755                  | 140 |                        |                                 | 275 | 55 | 575 | 19000 | I |
| 520 SG                   | 09765                  | 145 |                        |                                 | 305 | 60 | 640 | 29000 | I |
| 520 SG                   | 09775                  | 150 |                        |                                 | 305 | 60 | 640 | 28600 | I |
| 520 SG                   | 09785                  | 155 |                        |                                 | 305 | 60 | 640 | 28200 | I |
| 520 SG                   | 09795                  | 160 |                        |                                 | 305 | 60 | 640 | 28000 | I |
| 520 SG                   | 09805                  | 165 |                        |                                 | 342 | 70 | 715 | 37000 | I |
| 520 SG                   | 09815                  | 170 |                        |                                 | 342 | 70 | 715 | 36600 | I |
| 520 SG                   | 09825                  | 175 |                        |                                 | 342 | 70 | 715 | 36200 | I |
| 520 SG                   | 09835                  | 180 |                        |                                 | 342 | 70 | 715 | 35800 | I |
| 520 SG                   | 09845                  | 185 |                        |                                 | 342 | 70 | 715 | 35400 | I |
| 520 SG                   | 09855                  | 190 |                        |                                 | 392 | 78 | 800 | 39500 | I |
| 520 SG                   | 09865                  | 195 |                        |                                 | 392 | 78 | 800 | 39000 | I |
| 520 SG                   | 09875                  | 200 |                        |                                 | 392 | 78 | 800 | 38500 | I |
| 520 SG                   | 09885                  | 205 |                        |                                 | 392 | 78 | 800 | 38300 | I |
| 520 SG                   | 09895                  | 210 |                        |                                 | 392 | 78 | 800 | 38000 | I |
| 520 SG                   | 09905                  | 215 |                        |                                 | 392 | 78 | 800 | 38000 | I |
| 520 SG                   | 09915                  | 220 |                        |                                 | 415 | 80 | 800 | 37800 | I |

# Schraubenschlüssel Spanners & wrenches

## Schlag-Maulschlüssel

Maulstellungen: 15°

für schwerste Beanspruchung, Freiformschmiedestücke, Chrom-Vanadium-Stahl, phosphatiert

## Open end slugging wrench

positions of open end: 15°

for highest requirements, hammer forged, chrome vanadium steel, phosphatized

540 PH

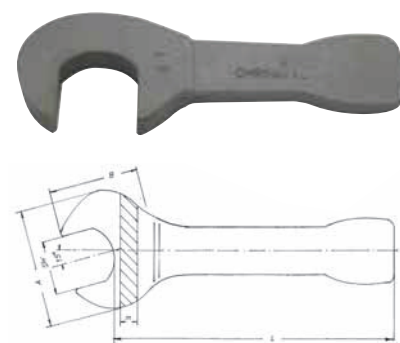

| Artikel-Nr.<br>Order-No. | Ident-Nr.<br>Ident-No. | mm  | A   | B   | m  | L   |       |   |
|--------------------------|------------------------|-----|-----|-----|----|-----|-------|---|
| 540 PH                   | 09987                  | 41  | 92  | 70  | 20 | 180 | 1600  | I |
| 540 PH                   | 09997                  | 46  | 96  | 74  | 20 | 200 | 1800  | I |
| 540 PH                   | 10007                  | 50  | 108 | 78  | 20 | 225 | 2200  | I |
| 540 PH                   | 10017                  | 55  | 115 | 86  | 25 | 250 | 3200  | I |
| 540 PH                   | 10027                  | 60  | 125 | 93  | 25 | 250 | 3200  | I |
| 540 PH                   | 10037                  | 65  | 142 | 101 | 30 | 280 | 3500  | I |
| 540 PH                   | 10047                  | 70  | 154 | 106 | 30 | 280 | 6500  | I |
| 540 PH                   | 10057                  | 75  | 160 | 112 | 35 | 320 | 6900  | I |
| 540 PH                   | 10067                  | 80  | 166 | 115 | 35 | 320 | 6900  | I |
| 540 PH                   | 10077                  | 85  | 175 | 128 | 35 | 320 | 7200  | I |
| 540 PH                   | 10087                  | 90  | 200 | 142 | 40 | 320 | 7900  | I |
| 540 PH                   | 10097                  | 95  | 200 | 142 | 40 | 360 | 9400  | I |
| 540 PH                   | 10107                  | 100 | 230 | 148 | 48 | 400 | 14000 | I |
| 540 PH                   | 10117                  | 105 | 240 | 148 | 48 | 400 | 14000 | I |
| 540 PH                   | 10127                  | 110 | 240 | 160 | 48 | 400 | 15000 | I |
| 540 PH                   | 10137                  | 115 | 250 | 175 | 56 | 425 | 17000 | I |
| 540 PH                   | 10147                  | 120 | 250 | 175 | 56 | 425 | 18000 | I |

Maulstellungen: 45°

positions of open end: 45°

| Artikel-Nr.<br>Order-No. | Ident-Nr.<br>Ident-No. | mm  | A   | B   | m  | L   |       |   |
|--------------------------|------------------------|-----|-----|-----|----|-----|-------|---|
| 540 PH                   | 10187                  | 41  | 92  | 70  | 20 | 180 | 1600  | I |
| 540 PH                   | 10197                  | 46  | 96  | 74  | 20 | 200 | 1800  | I |
| 540 PH                   | 10207                  | 50  | 108 | 78  | 20 | 225 | 2200  | I |
| 540 PH                   | 10217                  | 55  | 115 | 86  | 25 | 250 | 3200  | I |
| 540 PH                   | 10227                  | 60  | 125 | 93  | 25 | 250 | 3200  | I |
| 540 PH                   | 10237                  | 65  | 142 | 101 | 30 | 280 | 3500  | I |
| 540 PH                   | 10247                  | 70  | 154 | 106 | 30 | 280 | 6500  | I |
| 540 PH                   | 10257                  | 75  | 160 | 112 | 35 | 320 | 6900  | I |
| 540 PH                   | 10267                  | 80  | 166 | 115 | 35 | 320 | 6900  | I |
| 540 PH                   | 10277                  | 85  | 175 | 128 | 35 | 320 | 7200  | I |
| 540 PH                   | 10287                  | 90  | 200 | 142 | 40 | 320 | 7900  | I |
| 540 PH                   | 10297                  | 95  | 200 | 142 | 40 | 360 | 9400  | I |
| 540 PH                   | 10307                  | 100 | 230 | 148 | 48 | 400 | 14000 | I |
| 540 PH                   | 10317                  | 105 | 240 | 148 | 48 | 400 | 14000 | I |
| 540 PH                   | 10327                  | 110 | 240 | 160 | 48 | 400 | 15000 | I |
| 540 PH                   | 10337                  | 115 | 250 | 175 | 56 | 425 | 17000 | I |
| 540 PH                   | 10347                  | 120 | 250 | 175 | 56 | 425 | 18000 | I |

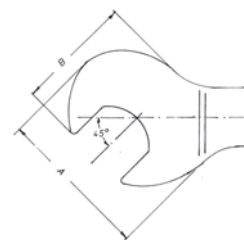

Maulstellungen: 90°

positions of open end: 90°

| Artikel-Nr.<br>Order-No. | Ident-Nr.<br>Ident-No. | mm  | A   | B   | m  | L   |       |   |
|--------------------------|------------------------|-----|-----|-----|----|-----|-------|---|
| 540 PH                   | 10387                  | 41  | 92  | 70  | 20 | 180 | 1600  | I |
| 540 PH                   | 10397                  | 46  | 96  | 74  | 20 | 200 | 1800  | I |
| 540 PH                   | 10407                  | 50  | 108 | 78  | 20 | 225 | 2200  | I |
| 540 PH                   | 10417                  | 55  | 115 | 86  | 25 | 250 | 3200  | I |
| 540 PH                   | 10427                  | 60  | 125 | 93  | 25 | 250 | 3200  | I |
| 540 PH                   | 10437                  | 65  | 142 | 101 | 30 | 280 | 3500  | I |
| 540 PH                   | 10447                  | 70  | 154 | 106 | 30 | 280 | 6500  | I |
| 540 PH                   | 10457                  | 75  | 160 | 112 | 35 | 320 | 6900  | I |
| 540 PH                   | 10467                  | 80  | 166 | 115 | 35 | 320 | 6900  | I |
| 540 PH                   | 10477                  | 85  | 175 | 128 | 35 | 320 | 7200  | I |
| 540 PH                   | 10487                  | 90  | 200 | 142 | 40 | 320 | 7900  | I |
| 540 PH                   | 10497                  | 95  | 200 | 142 | 40 | 360 | 9400  | I |
| 540 PH                   | 10507                  | 100 | 230 | 148 | 48 | 400 | 14000 | I |
| 540 PH                   | 10517                  | 105 | 240 | 148 | 48 | 400 | 14000 | I |
| 540 PH                   | 10527                  | 110 | 240 | 160 | 48 | 400 | 15000 | I |
| 540 PH                   | 10537                  | 115 | 250 | 175 | 56 | 425 | 17000 | I |
| 540 PH                   | 10547                  | 120 | 250 | 175 | 56 | 425 | 18000 | I |

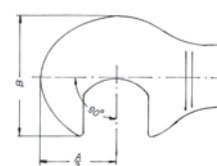

# Schraubenschlüssel Spanners & wrenches

## Einmaulschlüssel

Maulstellungen: 15°

für schwerste Zug-Beanspruchung, besonders lang,  
legierter Sonderstahl, phosphatiert

Single ended open jaw spanner

positions of open end: 15°

for highest tightening requirements, extra long, special  
alloy steel, phosphatized

560 PH

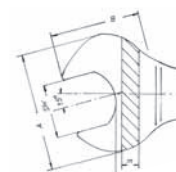

| Artikel-Nr.<br>Order-No. | Ident-Nr.<br>Ident-No. | mm | A   | B   | m  | L    |      |   |
|--------------------------|------------------------|----|-----|-----|----|------|------|---|
| 560 PH                   | I0597                  | 22 | 55  | 45  | 10 | 400  | 600  | I |
| 560 PH                   | I0607                  | 24 | 62  | 45  | 10 | 400  | 600  | I |
| 560 PH                   | I0617                  | 27 | 66  | 50  | 10 | 425  | 800  | I |
| 560 PH                   | I0627                  | 30 | 75  | 60  | 12 | 500  | 1200 | I |
| 560 PH                   | I0637                  | 32 | 75  | 60  | 12 | 500  | 1200 | I |
| 560 PH                   | I0647                  | 36 | 75  | 65  | 15 | 550  | 1500 | I |
| 560 PH                   | I0657                  | 41 | 90  | 75  | 16 | 600  | 2000 | I |
| 560 PH                   | I0667                  | 46 | 100 | 75  | 20 | 650  | 2300 | I |
| 560 PH                   | I0677                  | 50 | 110 | 85  | 20 | 700  | 3100 | I |
| 560 PH                   | I0687                  | 55 | 120 | 90  | 20 | 750  | 3700 | I |
| 560 PH                   | I0697                  | 60 | 132 | 100 | 20 | 800  | 4300 | I |
| 560 PH                   | I0707                  | 65 | 135 | 100 | 20 | 800  | 4500 | I |
| 560 PH                   | I0717                  | 70 | 172 | 105 | 20 | 850  | 5600 | I |
| 560 PH                   | I0727                  | 75 | 172 | 110 | 25 | 900  | 6700 | I |
| 560 PH                   | I0737                  | 80 | 172 | 120 | 25 | 1000 | 7600 | I |

Maulstellungen: 45°

positions of open end: 45°

| Artikel-Nr.<br>Order-No. | Ident-Nr.<br>Ident-No. | mm | A   | B   | m  | L    |      |   |
|--------------------------|------------------------|----|-----|-----|----|------|------|---|
| 560 PH                   | I0867                  | 22 | 55  | 45  | 10 | 400  | 600  | I |
| 560 PH                   | I0877                  | 24 | 62  | 45  | 10 | 400  | 600  | I |
| 560 PH                   | I0887                  | 27 | 66  | 50  | 10 | 425  | 800  | I |
| 560 PH                   | I0897                  | 30 | 75  | 60  | 12 | 500  | 1200 | I |
| 560 PH                   | I0907                  | 32 | 75  | 60  | 12 | 500  | 1200 | I |
| 560 PH                   | I0917                  | 36 | 75  | 65  | 15 | 550  | 1500 | I |
| 560 PH                   | I0927                  | 41 | 90  | 75  | 16 | 600  | 2000 | I |
| 560 PH                   | I0937                  | 46 | 100 | 75  | 20 | 650  | 2300 | I |
| 560 PH                   | I0947                  | 50 | 110 | 85  | 20 | 700  | 3100 | I |
| 560 PH                   | I0957                  | 55 | 120 | 90  | 20 | 750  | 3700 | I |
| 560 PH                   | I0967                  | 60 | 132 | 100 | 20 | 800  | 4300 | I |
| 560 PH                   | I0977                  | 65 | 135 | 100 | 20 | 800  | 4500 | I |
| 560 PH                   | I0987                  | 70 | 172 | 105 | 20 | 850  | 5600 | I |
| 560 PH                   | I0997                  | 75 | 172 | 110 | 25 | 900  | 6700 | I |
| 560 PH                   | I1007                  | 80 | 172 | 120 | 25 | 1000 | 7600 | I |

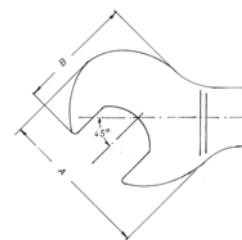

Maulstellungen: 90°

positions of open end: 90°

| Artikel-Nr.<br>Order-No. | Ident-Nr.<br>Ident-No. | mm | A   | B   | m  | L    |      |   |
|--------------------------|------------------------|----|-----|-----|----|------|------|---|
| 560 PH                   | I1167                  | 22 | 55  | 45  | 10 | 400  | 600  | I |
| 560 PH                   | I1177                  | 24 | 62  | 45  | 10 | 400  | 600  | I |
| 560 PH                   | I1187                  | 27 | 66  | 50  | 10 | 425  | 800  | I |
| 560 PH                   | I1197                  | 30 | 75  | 60  | 12 | 500  | 1200 | I |
| 560 PH                   | I1207                  | 32 | 75  | 60  | 12 | 500  | 1200 | I |
| 560 PH                   | I1217                  | 36 | 75  | 65  | 15 | 550  | 1500 | I |
| 560 PH                   | I1227                  | 41 | 90  | 75  | 16 | 600  | 2000 | I |
| 560 PH                   | I1237                  | 46 | 100 | 75  | 20 | 650  | 2300 | I |
| 560 PH                   | I1247                  | 50 | 110 | 85  | 20 | 700  | 3100 | I |
| 560 PH                   | I1257                  | 55 | 120 | 90  | 20 | 750  | 3700 | I |
| 560 PH                   | I1267                  | 60 | 132 | 100 | 20 | 800  | 4300 | I |
| 560 PH                   | I1277                  | 65 | 135 | 100 | 20 | 800  | 4500 | I |
| 560 PH                   | I1287                  | 70 | 172 | 105 | 20 | 850  | 5600 | I |
| 560 PH                   | I1297                  | 75 | 172 | 110 | 25 | 900  | 6700 | I |
| 560 PH                   | I1307                  | 80 | 172 | 120 | 25 | 1000 | 7600 | I |

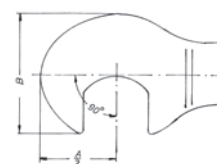

# Schraubenschlüssel Spanners & wrenches

Schlag-Ringschlüssel  
DIN 7444

Spezial-Stahl, stahlgrau (SG)  
Zwischengrößen auf Anfrage

Slugging ring wrench  
DIN 7444

special steel, steel grey (SG)  
special sizes on request

580 SG

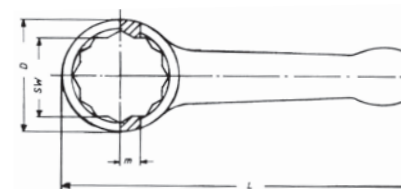

| Artikel-Nr.<br>Order-No. | Ident-Nr.<br>Ident-No. | mm  | Ident-Nr.<br>Ident-No. | AF"                             | D   | m  | L   |       |   |
|--------------------------|------------------------|-----|------------------------|---------------------------------|-----|----|-----|-------|---|
| 580 SG                   | 11425                  | 24  |                        |                                 | 43  | 15 | 165 | 400   | I |
| 580 SG                   | 11435                  | 27  | 11436                  | 1 <sup>1</sup> / <sub>16</sub>  | 46  | 16 | 180 | 400   | I |
| 580 SG                   |                        |     | 11437                  | 1 <sup>1</sup> / <sub>8</sub>   | 46  | 16 | 180 | 400   | I |
| 580 SG                   | 11445                  | 30  | 11446                  | 1 <sup>3</sup> / <sub>16</sub>  | 52  | 17 | 190 | 500   | I |
| 580 SG                   | 11455                  | 32  | 11456                  | 1 <sup>1</sup> / <sub>4</sub>   | 52  | 17 | 190 | 500   | I |
| 580 SG                   |                        |     | 11457                  | 1 <sup>5</sup> / <sub>16</sub>  | 52  | 17 | 190 | 500   | I |
| 580 SG                   | 11465                  | 36  | 11466                  | 1 <sup>3</sup> / <sub>8</sub>   | 58  | 18 | 205 | 500   | I |
| 580 SG                   |                        |     | 11467                  | 1 <sup>7</sup> / <sub>16</sub>  | 58  | 18 | 205 | 500   | I |
| 580 SG                   |                        |     | 11468                  | 1 <sup>1</sup> / <sub>2</sub>   | 58  | 18 | 205 | 500   | I |
| 580 SG                   | 11475                  | 41  | 11476                  | 1 <sup>9</sup> / <sub>16</sub>  | 66  | 20 | 230 | 800   | I |
| 580 SG                   |                        |     | 11477                  | 1 <sup>5</sup> / <sub>8</sub>   | 66  | 20 | 230 | 800   | I |
| 580 SG                   |                        |     | 11478                  | 1 <sup>11</sup> / <sub>16</sub> | 66  | 20 | 230 | 800   | I |
| 580 SG                   | 11485                  | 46  | 11486                  | 1 <sup>3</sup> / <sub>4</sub>   | 74  | 22 | 240 | 1000  | I |
| 580 SG                   |                        |     | 11487                  | 1 <sup>13</sup> / <sub>16</sub> | 74  | 22 | 240 | 1000  | I |
| 580 SG                   |                        |     | 11488                  | 1 <sup>7</sup> / <sub>8</sub>   | 74  | 22 | 240 | 1000  | I |
| 580 SG                   | 11495                  | 50  | 11496                  | 1 <sup>15</sup> / <sub>16</sub> | 80  | 24 | 255 | 1100  | I |
| 580 SG                   |                        |     | 11497                  | 2                               | 80  | 24 | 255 | 1100  | I |
| 580 SG                   |                        |     | 11498                  | 2 <sup>1</sup> / <sub>16</sub>  | 80  | 24 | 255 | 1100  | I |
| 580 SG                   | 11505                  | 55  | 11506                  | 2 <sup>1</sup> / <sub>8</sub>   | 86  | 25 | 270 | 1500  | I |
| 580 SG                   |                        |     | 11507                  | 2 <sup>3</sup> / <sub>16</sub>  | 86  | 25 | 270 | 1500  | I |
| 580 SG                   |                        |     | 11508                  | 2 <sup>1</sup> / <sub>4</sub>   | 86  | 25 | 270 | 1500  | I |
| 580 SG                   | 11515                  | 60  | 11516                  | 2 <sup>5</sup> / <sub>16</sub>  | 93  | 26 | 280 | 1800  | I |
| 580 SG                   |                        |     | 11517                  | 2 <sup>3</sup> / <sub>8</sub>   | 93  | 26 | 280 | 1800  | I |
| 580 SG                   |                        |     | 11518                  | 2 <sup>7</sup> / <sub>16</sub>  | 93  | 26 | 280 | 1800  | I |
| 580 SG                   | 11525                  | 65  | 11526                  | 2 <sup>1</sup> / <sub>2</sub>   | 102 | 30 | 300 | 2200  | I |
| 580 SG                   |                        |     | 11527                  | 2 <sup>9</sup> / <sub>16</sub>  | 102 | 30 | 300 | 2200  | I |
| 580 SG                   |                        |     | 11528                  | 2 <sup>5</sup> / <sub>8</sub>   | 102 | 30 | 300 | 2200  | I |
| 580 SG                   | 11535                  | 70  | 11536                  | 2 <sup>3</sup> / <sub>4</sub>   | 110 | 33 | 330 | 3300  | I |
| 580 SG                   |                        |     | 11537                  | 2 <sup>13</sup> / <sub>16</sub> | 110 | 33 | 330 | 3300  | I |
| 580 SG                   | 11545                  | 75  | 11538                  | 2 <sup>7</sup> / <sub>8</sub>   | 110 | 33 | 330 | 3300  | I |
| 580 SG                   |                        |     | 11546                  | 2 <sup>15</sup> / <sub>16</sub> | 110 | 33 | 330 | 3300  | I |
| 580 SG                   |                        |     | 11547                  | 3                               | 110 | 33 | 330 | 3300  | I |
| 580 SG                   | 11555                  | 80  | 11556                  | 3 <sup>1</sup> / <sub>8</sub>   | 126 | 36 | 360 | 4500  | I |
| 580 SG                   | 11565                  | 85  | 11557                  | 3 <sup>1</sup> / <sub>4</sub>   | 126 | 36 | 360 | 4500  | I |
| 580 SG                   |                        |     | 11566                  | 3 <sup>3</sup> / <sub>8</sub>   | 126 | 36 | 360 | 4300  | I |
| 580 SG                   | 11575                  | 90  | 11576                  | 3 <sup>1</sup> / <sub>2</sub>   | 142 | 40 | 390 | 5500  | I |
| 580 SG                   | 11585                  | 95  | 11577                  | 3 <sup>5</sup> / <sub>8</sub>   | 142 | 40 | 420 | 5300  | I |
| 580 SG                   |                        |     | 11586                  | 3 <sup>3</sup> / <sub>4</sub>   | 155 | 45 | 420 | 6500  | I |
| 580 SG                   | 11595                  | 100 | 11596                  | 3 <sup>7</sup> / <sub>8</sub>   | 155 | 45 | 420 | 6500  | I |
| 580 SG                   | 11605                  | 105 | 11597                  | 4                               | 155 | 45 | 420 | 6500  | I |
| 580 SG                   |                        |     | 11606                  | 4 <sup>1</sup> / <sub>8</sub>   | 155 | 45 | 420 | 6200  | I |
| 580 SG                   | 11615                  | 110 | 11616                  | 4 <sup>1</sup> / <sub>4</sub>   | 170 | 48 | 450 | 8000  | I |
| 580 SG                   | 11625                  | 115 | 11626                  | 4 <sup>1</sup> / <sub>2</sub>   | 170 | 48 | 450 | 7800  | I |
| 580 SG                   |                        |     | 11627                  | 4 <sup>5</sup> / <sub>8</sub>   | 170 | 48 | 450 | 7800  | I |
| 580 SG                   | 11635                  | 120 | 11636                  | 4 <sup>3</sup> / <sub>4</sub>   | 182 | 54 | 480 | 10000 | I |
| 580 SG                   | 11645                  | 125 | 11646                  | 5                               | 182 | 54 | 480 | 9700  | I |
| 580 SG                   | 11655                  | 130 |                        |                                 | 202 | 58 | 520 | 13200 | I |
| 580 SG                   | 11665                  | 135 |                        |                                 | 202 | 58 | 520 | 13000 | I |
| 580 SG                   | 11675                  | 140 |                        |                                 | 210 | 58 | 520 | 18500 | I |
| 580 SG                   | 11685                  | 145 |                        |                                 | 228 | 64 | 580 | 18500 | I |
| 580 SG                   | 11695                  | 150 |                        |                                 | 228 | 64 | 580 | 18200 | I |
| 580 SG                   | 11705                  | 155 |                        |                                 | 228 | 64 | 580 | 18000 | I |
| 580 SG                   | 11715                  | 160 |                        |                                 | 240 | 64 | 580 | 17800 | I |
| 580 SG                   | 11725                  | 165 |                        |                                 | 265 | 70 | 650 | 26500 | I |
| 580 SG                   | 11735                  | 170 |                        |                                 | 265 | 70 | 650 | 26000 | I |
| 580 SG                   | 11745                  | 175 |                        |                                 | 265 | 70 | 650 | 25500 | I |
| 580 SG                   | 11755                  | 180 |                        |                                 | 265 | 70 | 650 | 25000 | I |
| 580 SG                   | 11765                  | 185 |                        |                                 | 290 | 75 | 700 | 33000 | I |
| 580 SG                   | 11775                  | 190 |                        |                                 | 290 | 75 | 700 | 32500 | I |
| 580 SG                   | 11785                  | 195 |                        |                                 | 290 | 75 | 700 | 32000 | I |
| 580 SG                   | 11795                  | 200 |                        |                                 | 290 | 75 | 700 | 31500 | I |
| 580 SG                   | 11805                  | 205 |                        |                                 | 320 | 80 | 750 | 32000 | I |
| 580 SG                   | 11815                  | 210 |                        |                                 | 320 | 80 | 750 | 32000 | I |
| 580 SG                   | 11825                  | 215 |                        |                                 | 320 | 80 | 750 | 32000 | I |
| 580 SG                   | 11835                  | 220 |                        |                                 | 320 | 80 | 750 | 32000 | I |
| 580 SG                   | 11845                  | 225 |                        |                                 | 320 | 80 | 750 | 31600 | I |
| 580 SG                   | 11855                  | 230 |                        |                                 | 320 | 80 | 750 | 31000 | I |



# Schraubenschlüssel Spanners & wrenches



## Schlag-Ringschlüssel

extra Qualität „stärker als die Schraube“, besonders dünnwandige, hohe Ringe, Chrom-Vanadium-Stahl, phosphatiert, für tieferliegende Schrauben, Kombinationsmöglichkeit mit unserem Schlagschlüssel-Einsatz No. 625 PH

## Slugging ring wrench

extra quality „stronger than the bolt“, especially thin-walled, but high rings, chrome vanadium steel, phosphatized, for deeper seated bolts, combine with our impact socket Nr. 625 PH

620 PH

| Artikel-Nr.<br>Order-No. | Ident-Nr.<br>Ident-No. | mm  | D   | h  | L   |  |  |
|--------------------------|------------------------|-----|-----|----|-----|---|---|
| 620 PH                   | I1927                  | 30  | 42  | 24 | 190 | 500   | I   |
| 620 PH                   | I1937                  | 32  | 47  | 24 | 195 | 500   | I   |
| 620 PH                   | I1947                  | 36  | 52  | 26 | 195 | 600   | I   |
| 620 PH                   | I1957                  | 41  | 59  | 29 | 200 | 800   | I   |
| 620 PH                   | I1967                  | 46  | 65  | 32 | 250 | 1000  | I   |
| 620 PH                   | I1977                  | 50  | 70  | 35 | 280 | 1300  | I   |
| 620 PH                   | I1987                  | 55  | 76  | 38 | 300 | 1700  | I   |
| 620 PH                   | I1997                  | 60  | 83  | 42 | 300 | 2000  | I   |
| 620 PH                   | I2007                  | 65  | 90  | 45 | 325 | 2600  | I   |
| 620 PH                   | I2017                  | 70  | 97  | 48 | 365 | 3800  | I   |
| 620 PH                   | I2027                  | 75  | 104 | 51 | 365 | 4500  | I   |
| 620 PH                   | I2037                  | 80  | 110 | 57 | 440 | 5800  | I   |
| 620 PH                   | I2047                  | 85  | 117 | 57 | 440 | 6300  | I   |
| 620 PH                   | I2057                  | 90  | 124 | 60 | 445 | 7200  | I   |
| 620 PH                   | I2067                  | 95  | 131 | 67 | 450 | 8500  | I   |
| 620 PH                   | I2077                  | 100 | 137 | 67 | 460 | 9800  | I   |
| 620 PH                   | I2087                  | 105 | 146 | 73 | 460 | 11000   | I   |
| 620 PH                   | I2097                  | 110 | 156 | 80 | 505 | 14500   | I   |
| 620 PH                   | I2107                  | 115 | 162 | 80 | 505 | 15000   | I   |
| 620 PH                   | I2117                  | 120 | 168 | 83 | 530 | 17000   | I   |

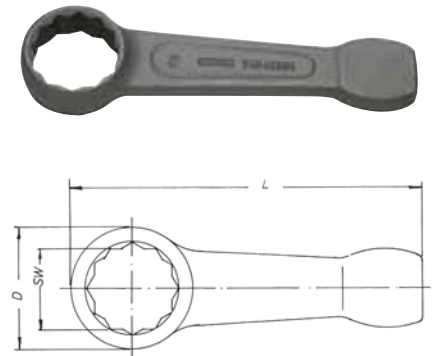



## Schlagschlüssel-Einsatz

gleicher Innen- und Außensechskant, zur Verwendung mit Schlagschlüssel, No. 620 PH, für tieferliegende Schrauben, zusätzlicher Innen-Vierkant, Chrom-Vanadium-Stahl, phosphatiert

## Heavy duty socket for slugging wrenches

male & female hexagon of same size, for use with slugging ring wrenches No. 620 PH for deeper seated bolts, female square drive adapter, chrome vanadium steel, phosphatized

625 PH

| Artikel-Nr.<br>Order-No. | Ident-Nr.<br>Ident-No. | mm  | D   | T  | m  | L      |  |  |   |
|--------------------------|------------------------|-----|-----|----|----|--------|---|---|---|
| 625 PH                   | I2157                  | 41  | 59  | 28 | 35 | 80     | 740   | I   |   |
| 625 PH                   | I2167                  | 46  | 65  | 30 | 35 | 82     | 900   | I   |   |
| 625 PH                   | I2177                  | 50  | 70  | 32 | 35 | 85     | 1120  | I   |   |
| 625 PH                   | I2187                  | 55  | 76  | 35 | 35 | 90     | 1420  | I   |   |
| 625 PH                   | I2197                  | 60  | 83  | 37 | 35 | 1"     | 95  | 1680  | I |
| 625 PH                   | I2207                  | 65  | 91  | 38 | 35 | 100    | 2200  | I   |   |
| 625 PH                   | I2217                  | 70  | 97  | 41 | 35 | 108    | 2830  | I   |   |
| 625 PH                   | I2227                  | 75  | 104 | 44 | 35 | 112    | 3220  | I   |   |
| 625 PH                   | I2237                  | 80  | 110 | 46 | 35 | 120    | 3900  | I   |   |
| 625 PH                   | I2247                  | 85  | 117 | 50 | 45 | 127    | 4670  | I   |   |
| 625 PH                   | I2257                  | 90  | 124 | 54 | 45 | 130    | 5510  | I   |   |
| 625 PH                   | I2267                  | 95  | 131 | 56 | 45 | 140    | 6740  | I   |   |
| 625 PH                   | I2277                  | 100 | 137 | 60 | 45 | 1 1/2" | 145   | 7580  | I |
| 625 PH                   | I2287                  | 105 | 153 | 60 | 45 | 155    | 8910  | I   |   |
| 625 PH                   | I2297                  | 110 | 156 | 60 | 45 | 165    | 11300   | I   |   |
| 625 PH                   | I2307                  | 115 | 174 | 65 | 45 | 165    | 12340   | I   |   |
| 625 PH                   | I2317                  | 120 | 174 | 65 | 45 | 170    | 14500   | I   |   |

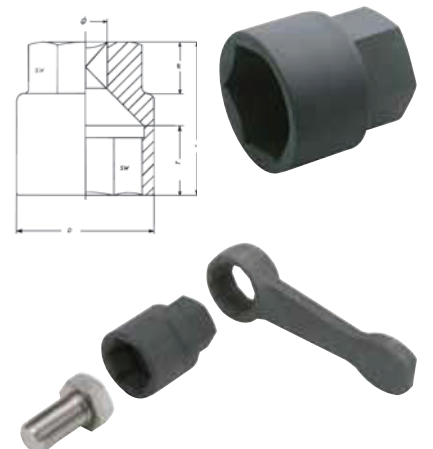



# Schraubenschlüssel Spanners & wrenches

Schlagschlüssel für Innensechskant-Schrauben   
Chrom-Vanadium-Stahl, phosphatiert, zwei Ausführungen

Slugging wrench for allen screws   
chrome vanadium steel, phosphatized,

630 PH

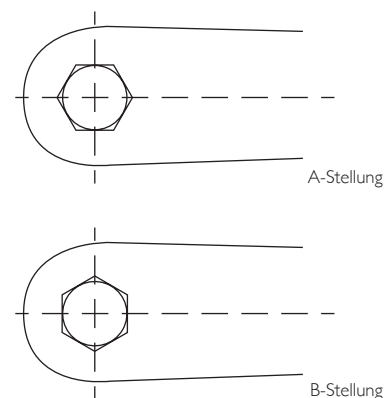

| Artikel-Nr.<br>Order-No. | Ident-Nr.<br>Ident-No. | Form<br>Style |  mm |  | A  | C   | D   | L   |  |
|--------------------------|------------------------|---------------|--|--|----|-----|-----|-----|---|
| 630 PH                   | 630 1700 040           | A             | 17   |  | 30 | 62  | 52  | 195 | I   |
| 630 PH                   | 630 1701 040           | B             | 17   |  | 30 | 62  | 52  | 195 | I   |
| 630 PH                   | 630 1900 040           | A             | 19   |  | 30 | 62  | 52  | 195 | I   |
| 630 PH                   | 630 1901 040           | B             | 19   |  | 30 | 62  | 52  | 195 | I   |
| 630 PH                   | 630 2200 040           | A             | 22   |  | 30 | 62  | 52  | 195 | I   |
| 630 PH                   | 630 2201 040           | B             | 22   |  | 30 | 62  | 52  | 195 | I   |
| 630 PH                   | 630 2400 040           | A             | 24   |  | 30 | 62  | 52  | 195 | I   |
| 630 PH                   | 630 2401 040           | B             | 24   |  | 30 | 62  | 52  | 195 | I   |
| 630 PH                   | 630 2700 040           | A             | 27   |  | 30 | 68  | 52  | 195 | I   |
| 630 PH                   | 630 2701 040           | B             | 27   |  | 30 | 68  | 52  | 195 | I   |
| 630 PH                   | 630 3000 040           | A             | 30   |  | 30 | 74  | 58  | 195 | I   |
| 630 PH                   | 630 3001 040           | B             | 30   |  | 30 | 74  | 58  | 195 | I   |
| 630 PH                   | 630 3200 040           | A             | 32   |  | 30 | 74  | 58  | 195 | I   |
| 630 PH                   | 630 3201 040           | B             | 32   |  | 30 | 74  | 58  | 195 | I   |
| 630 PH                   | 630 3600 040           | A             | 36   |  | 30 | 80  | 58  | 195 | I   |
| 630 PH                   | 630 3601 040           | B             | 36   |  | 30 | 80  | 58  | 195 | I   |
| 630 PH                   | 630 4100 040           | A             | 41   |  | 30 | 83  | 72  | 250 | I   |
| 630 PH                   | 630 4101 040           | B             | 41   |  | 30 | 83  | 72  | 250 | I   |
| 630 PH                   | 630 4600 040           | A             | 46   |  | 30 | 89  | 72  | 250 | I   |
| 630 PH                   | 630 4601 040           | B             | 46   |  | 30 | 89  | 72  | 250 | I   |
| 630 PH                   | 630 5000 040           | A             | 50   |  | 30 | 93  | 88  | 300 | I   |
| 630 PH                   | 630 5001 040           | B             | 50   |  | 30 | 93  | 88  | 300 | I   |
| 630 PH                   | 630 5500 040           | A             | 55   |  | 30 | 95  | 88  | 300 | I   |
| 630 PH                   | 630 5501 040           | B             | 55   |  | 30 | 95  | 88  | 300 | I   |
| 630 PH                   | 630 6000 040           | A             | 60   |  | 30 | 99  | 88  | 300 | I   |
| 630 PH                   | 630 6001 040           | B             | 60   |  | 30 | 99  | 88  | 300 | I   |
| 630 PH                   | 630 6500 040           | A             | 65   |  | 30 | 100 | 104 | 300 | I   |
| 630 PH                   | 630 6501 040           | B             | 65   |  | 30 | 100 | 104 | 300 | I   |
| 630 PH                   | 6307000 040            | A             | 70   |  | 30 | 107 | 124 | 440 | I   |
| 630 PH                   | 630 7001 040           | B             | 70   |  | 30 | 107 | 124 | 440 | I   |
| 630 PH                   | 630 7500 040           | A             | 75   |  | 30 | 107 | 124 | 440 | I   |
| 630 PH                   | 630 7501 040           | B             | 75   |  | 30 | 107 | 124 | 440 | I   |
| 630 PH                   | 630 8000 040           | A             | 80   |  | 30 | 112 | 124 | 440 | I   |
| 630 PH                   | 630 8001 040           | B             | 80   |  | 30 | 112 | 124 | 440 | I   |
| 630 PH                   | 630 9000 040           | A             | 90   |  | 30 | 130 | 164 | 500 | I   |
| 630 PH                   | 630 9001 040           | B             | 90   |  | 30 | 130 | 164 | 500 | I   |
| 630 PH                   | 630 9500 040           | A             | 95   |  | 30 | 130 | 164 | 500 | I   |
| 630 PH                   | 630 9501 040           | B             | 95   |  | 30 | 130 | 164 | 500 | I   |



Schlagschlüssel COMPACT   
Chrom-Vanadium-Stahl, phosphatiert, für schwere Beanspruchung, insbesondere bei beengten Platzverhältnissen

Slugging ring wrench COMPACT   
chrome vanadium steel, phosphatized, for highest demands, especially for use on confined areas

640 PH

| Artikel-Nr.<br>Order-No. | Ident-Nr.<br>Ident-No. |  mm |  | D  | h  |  |  |
|--------------------------|------------------------|--|--|----|----|---|---|
| 640 PH                   | 640 0270 040           | 27   |  | 52 | 25 | 270   | I   |
| 640 PH                   | 640 0300 040           | 30   |  | 54 | 27 | 290   | I   |
| 640 PH                   | 640 0320 040           | 32   |  | 56 | 27 | 300   | I   |
| 640 PH                   | 640 0360 040           | 36   |  | 62 | 30 | 380   | I   |
| 640 PH                   | 640 0410 040           | 41   |  | 68 | 33 | 460   | I   |
| 640 PH                   | 640 0460 040           | 46   |  | 78 | 35 | 460   | I   |
| 640 PH                   | 640 0500 040           | 50   |  | 82 | 38 | 820   | I   |
| 640 PH                   | 640 0550 040           | 55   |  | 90 | 40 | 980   | I   |
| 640 PH                   | 640 0600 040           | 60   |  | 98 | 40 | 1250  | I   |

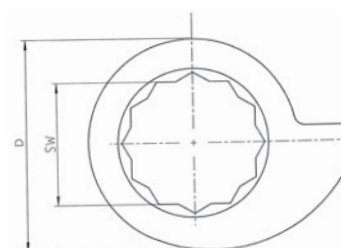

# Schraubenschlüssel Spanners & wrenches

## Ringverlängerung 1/2"

hochwertiger Chrom-Vanadium-Stahl, phosphatiert

## Ring extension 1/2"

high quality chrome vanadium steel, phosphatized

| Artikel-Nr.<br>Order-No. | Ident-Nr.<br>Ident-No. | SW | L    | E  | H  |
|--------------------------|------------------------|----|------|----|----|
| 2364 PH                  | 023640080700           | 8  | 70   | 50 | 6  |
| 2364 PH                  | 023640090700           | 9  | 70   | 50 | 6  |
| 2364 PH                  | 023640100720           | 10 | 72   | 50 | 6  |
| 2364 PH                  | 023640110720           | 11 | 72   | 50 | 6  |
| 2364 PH                  | 023640120740           | 12 | 74   | 50 | 8  |
| 2364 PH                  | 023640130740           | 13 | 74   | 50 | 8  |
| 2364 PH                  | 023640140740           | 14 | 74   | 50 | 8  |
| 2364 PH                  | 023640150750           | 15 | 75   | 50 | 13 |
| 2364 PH                  | 023640160770           | 16 | 77   | 50 | 13 |
| 2364 PH                  | 023640170790           | 17 | 79   | 50 | 13 |
| 2364 PH                  | 023640180800           | 18 | 80   | 50 | 13 |
| 2364 PH                  | 023640190800           | 19 | 80   | 50 | 13 |
| 2364 PH                  | 023640210815           | 21 | 81,5 | 50 | 13 |
| 2364 PH                  | 023640220815           | 22 | 81,5 | 50 | 13 |
| 2364 PH                  | 023640240840           | 24 | 84   | 50 | 15 |
| 2364 PH                  | 023640270940           | 27 | 94   | 55 | 15 |
| 2364 PH                  | 023640301000           | 30 | 100  | 60 | 20 |

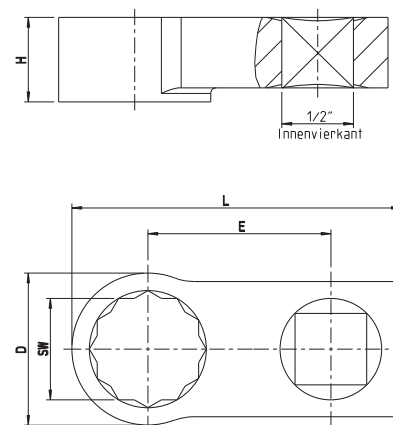

2364 PH

## Ringverlängerung 3/4"

hochwertiger Chrom-Vanadium-Stahl, phosphatiert

## Ring extension 3/4"

high quality chrome vanadium steel, phosphatized

| Artikel-Nr.<br>Order-No. | Ident-Nr.<br>Ident-No. | SW | L   | E   | H  |
|--------------------------|------------------------|----|-----|-----|----|
| 2365 PH                  | 023650170820           | 17 | 82  | 55  | 20 |
| 2365 PH                  | 023650190830           | 19 | 83  | 55  | 20 |
| 2365 PH                  | 023650210880           | 21 | 88  | 55  | 25 |
| 2365 PH                  | 023650220890           | 22 | 89  | 55  | 25 |
| 2365 PH                  | 023650240920           | 24 | 92  | 55  | 25 |
| 2365 PH                  | 023650270940           | 27 | 94  | 55  | 25 |
| 2365 PH                  | 023650301010           | 30 | 101 | 60  | 25 |
| 2365 PH                  | 023650321020           | 32 | 102 | 60  | 25 |
| 2365 PH                  | 023650361030           | 36 | 103 | 60  | 30 |
| 2365 PH                  | 023650411070           | 41 | 107 | 60  | 30 |
| 2365 PH                  | 023650461200           | 46 | 120 | 70  | 30 |
| 2365 PH                  | 023650501230           | 50 | 123 | 70  | 30 |
| 2365 PH                  | 023650551400           | 55 | 140 | 85  | 30 |
| 2365 PH                  | 023650601730           | 60 | 173 | 100 | 30 |

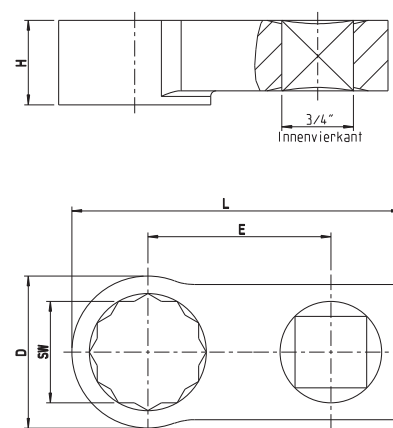

2365 PH



Ringverlängerung  
ring extension



offene Ringverlängerung  
open ring extension



Sonder-Ringverlängerung  
special ring extension

# Schraubenschlüssel Spanners & wrenches

## Ringverlängerung I''

hochwertiger Chrom-Vanadium-Stahl, phosphatiert

## Ring extension I''

high quality chrome vanadium steel, phosphatized

## 2366 PH

| Artikel-Nr.<br>Order-No. | Ident-Nr.<br>Ident-No. | SW | L     | E   | H  |
|--------------------------|------------------------|----|-------|-----|----|
| 2366 PH                  | 023660270940           | 27 | 94    | 55  | 25 |
| 2366 PH                  | 023660301115           | 30 | 111,5 | 65  | 25 |
| 2366 PH                  | 023660321130           | 32 | 113   | 65  | 25 |
| 2366 PH                  | 023660361160           | 36 | 116   | 65  | 30 |
| 2366 PH                  | 023660411250           | 41 | 125   | 70  | 30 |
| 2366 PH                  | 023660461330           | 46 | 133   | 75  | 30 |
| 2366 PH                  | 023660501360           | 50 | 136   | 75  | 35 |
| 2366 PH                  | 023660551550           | 55 | 155   | 90  | 38 |
| 2366 PH                  | 023360601630           | 60 | 163   | 95  | 41 |
| 2366 PH                  | 023660651730           | 65 | 173   | 100 | 44 |
| 2366 PH                  | 023660701830           | 70 | 183   | 105 | 47 |
| 2366 PH                  | 023660752080           | 75 | 208   | 115 | 50 |
| 2366 PH                  | 023660802150           | 80 | 215   | 120 | 57 |

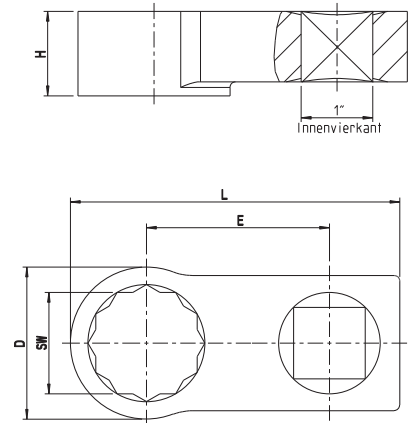

## Offene Ringverlängerungen

Wir können alle Ringverlängerungen auch in einer offenen Ausführung liefern. Hierfür berechnen wir einen Fertigungsaufschlag von 30%.

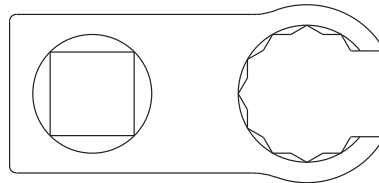
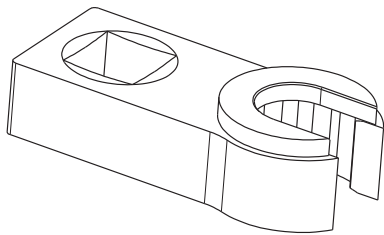

## open ring extensions

Also we can deliver all ring extensions in an open design. For the open design we calculate a surcharge of 30%.

## Sonder-Ringverlängerungen

Wir fertigen Verlängerungen nach Ihrer Konstruktion oder konstruieren nach Ihren Vorgaben.

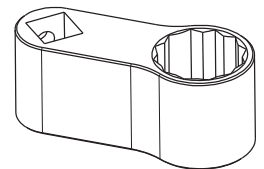
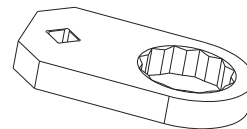
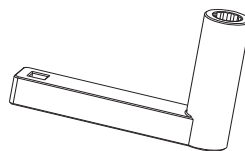
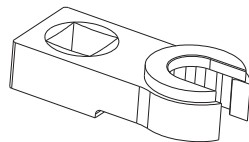
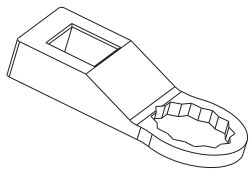

## special ring extensions

We produce extensions according to your design or designs according to your demands

